

General Catalog 2025

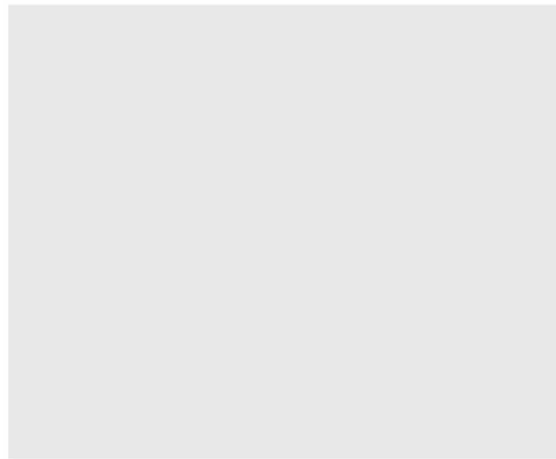

-  **S7-Panel-PLC**
-  **S7-Compact-PLC**
-  **S7-Panel-HMI**
-  **Periphery**
-  **Software**
-  **Energy management**
-  **S7-IIoT-Gateway**

General Catalog 2025



Content

About INSEVIS.....	4
Data to INSEVIS-S7-CPU's.....	6
Possible S7-System architectures.....	8
Customized versions of serial products.....	9
S7-Panel-PLC.....	12
Accessories for S7-Panel-PLCs.....	20
S7-Compact-PLC.....	22
Accessories for S7-Compact-PLC.....	26
S7-Panel-HMI.....	28
Accessories for S7-Panel-HMIs.....	32
Periphery.....	34
Decentral head stations.....	36
Periphery module DI16 (16 digital inputs 24V).....	37
Periphery module DIO16 (16 digital in- or outputs 24V / 0,5A).....	38
Periphery module DO4R (4 relay outputs 230V) / 3A.....	39
Periphery module AI8 (8 analog inputs).....	40
Periphery module MIO84 (8 digital- and 4 analog in- or outputs).....	41
Periphery module AI4O4 (4 analog in- and 4 analog outputs).....	42
Periphery module AI8O2 (8 analog in- and 2 analog outputs).....	43
Periphery module RTD8O2 (8 analog in- and 2 analog outputs).....	44
Function module DIO8-Z (2 encoder channels and 2 digital in- or outputs).....	45
Function module E-Mess UI (3 voltage- and 4 current transformer inputs for L1-L3, N).....	46
Accessories for periphery.....	47
Software.....	50
ConfigStage.....	52
ServiceStage.....	53
VisuStage.....	54
RemoteStage.....	56
Energy management.....	60
System topologies – exclusive solutions for power metering or load management.....	61
System topologies – mixed solutions for power metering and load management.....	62
S7-IIoT-Gateway.....	64



About INSEVIS

Welcome to the independent mind zone

We at INSEVIS are first and foremost meticulous technicians whose main concern is are long-term and perfectly functioning products. In the last years INSEVIS became to one of the leading supplier of S7-system components, what complete existing products and expand the horizon of possible applications. Primarily we are meticulously working German engineers, whose most important concern are perfectly working products. For us satisfied customers and long-termed business relations count much more than a fast business. Therefore we love to work with independent and open minded people to develop new impulses for the S7-community. Maybe we can change the world a little bit to a better one, reducing efforts, creating new ideas and helping to realize it faster than others do – **would you join us?**

KEEP S7
SMART &
SIMPLE

Simple handling ...

Ergonomic software tools for parametrization and configuration, installed within a couple of minutes, without high requirements to the PC or monitor size. Easy to operate and also clearly to recognize after months with other jobs. Self-explanatory for users of WinCCflexible from Siemens. The easy integration of INSEVIS-products into the S7-world is deemed to be exemplary for other suppliers. Complex communication settings will be solved intuitively in a graphic way and expand existing S7-world without problems. Clever special functions help to realize complex tasks with simple methods.

... ergonomic software for anybody and anytime ✓

Clear license- and compatibility policy ...

INSEVIS stands for honest license policy, supplying you consistent cost advantages. Our sovereignty over BIOS, own firmware and own configuration tools allows us the best license policy – the renunciation of licenses. That's why INSEVIS offers the whole range of software packages for free (respectively one with a mini-license fee). Each version is compatible to older versions. Thereby is an existing project readable with a new software version or by a device with a new firmware. There are no incompatibilities, which makes life difficult to our customers.

... software without runtime-license and power tags ✓

Independence and inexchangeability...

Technical benefit and customized branding with logo- and article numbers with the first device help INSEVIS-customers to keep their independence and to defend against trials of copy and recalculation. A effective know-how-protection cares for a long termed profit of its own work without being dependent or exchangeable. As supplement to existing system components INSEVIS develops and produces customized boards what care for a sustainable benefit.

... effective know-how and ROI-protection ✓



S7-system components ...

The range of INSEVIS- product families enables an integrated solution and easy to handle for small and medium automation applications with latest technology, very high quality level and with additional interfaces like CANopen® and Modbus, to be configured easily. A large and multilingual visualization in a modern design is done by a few clicks and the work flow is known by every WinCCflexible® user. It can be simulated on the visualization PC and is accessible remote for free.

... supplement of existing S7-solutions ✓

Step®7 programmability ...

INSEVIS-S7-CPU's are programmable by STEP 7® - AWL, KOP, FUP, S7-SCL, S7-Graph from Siemens and in general command-compatible to Siemens-CPU S7-315-2PN DP. Some special INSEVIS blocks expand the functionality and allow outstanding solutions. The S7-programming will be done by good known tools Simatic®-Manager V5.5 or by the newer TIA-Portal® from Siemens always. Variables import and synchronization will keep visualization close to your S7-project.

... to minimize costs and risks ✓

German quality and proper service ...

Development, PCB-design and -production, test and mounting of all INSEVIS products - all this is made in Germany. So every product is a proof for the combination of German engineering and economy and is available with a certification of German origin. Our service is provided by engineers, who really can help immediately instead of refusing inquiries and keeping customers away. Manuals, sample programs and YouTube-videos are always available in English language too.

... basis for long termed cooperation ✓



INSEVIS operates a yearly certified quality management system ref. to DIN EN ISO 9001.

All suppliers of INSEVIS obligate to this quality management and contribute to the high quality level of INSEVIS products.

Already during planning these product families one goal was indicated as most important: to design highest quality and ergonomics into all products.

These products were put into comprehensive validation tests before they were produced in selected and certified production lines.

INSEVIS Made in Germany

Uncompromising quality and maximal customer's value in each detail are the highest business objectives at INSEVIS what dominates all thinking and acting of the whole company.



Data to INSEVIS-S7-CPU

INSEVIS-CPU are not single products, they are the “heart” to be placed in every PLC or HMI to supply their special properties there. When they are used in Panel-HMIs the PLC-functionality is disabled and the one and only communication channel is Ethernet RFC1006 (S7-communication).

Devices with CPU-V and CPU-P fit properly to small and medium sized applications in the low cost-areas of Panel-PLCs with high graded visualization (Typ V best for 3,5 to 5,7" and Typ P better for 7 to 10,2") and with lots of communication interfaces. Profibus is optional available.

CPU-V and CPU-P



Property	Technical data
OB, FC, FB, DB Local data Depth of nesting	each 1.024 32kByte (2kByte per block) up to 16 code blocks
Number of inputs and outputs Process image	in each case 2.048 Byte (16.384 Bit) addressable in each case 2.048 Byte (default set is 128 Byte)
Number of memory bytes Number of clock memory	2.048 (remanence adjustable, default set is 0..15) 8 (1 Markerbyte)
Number of timer, counter	in each case 256 (each remanence adjustable, default set is 0)
Real-time clock elapsed hour counter	yes (accumulator-backed hardware clock) 1 (32Bit, resolution 1h)
Program language Program system	STEP 7® - STL, LAD, FBD, S7-SCL, S7-Graph from Siemens SIMATIC® Manager from Siemens or products compatible to it
Operating system Program unit to reference	compatible to S7-300® from Siemens CPU 315-2DP/PN (6ES7 315-2EH14-0AB0 firmware V3.1 Siemens)
Communication	
Serial interfaces (protocols)	COM1: RS 232 (free ASCII) COM2: RS 485 (free ASCII, Modbus-RTU)
Ethernet (protocols)	Ethernet: 10/100 MBit with CP343 functionality (RFC1006, TCP, UDP, Modbus-TCP)
CAN (protocols)	CAN-telegrams (Layer 2), compatible to CANopen® master 10 kBaud ... 1 MBaud
optional interfaces (protocols)	Profibus DP V0 master / slave 9,6kBaud ... 12 MBaud
Periphery access	
Decentral periphery	- INSEVIS- periphery (with automatic configuration via „ConfigStage“) - diverse external periphery families (Modbus RTU/TCP, CAN) - all CANopen® slaves according to DS401 - all Profibus DP-V0-slaves

Memory	CPU-V	CPU-P	Remark:
Working memory, thereof batt.-buffered	512kB (256 kByte remanent)	640kB (384 kByte remanent)	The S7-program data are kept in the flash memory (Flash) and the S7-process data are kept in the battery-buffered RAM (SRAM) and not on the Micro-SD-card. This is for archiving and backup only.
Load memory	2MB flash memory	2MB flash memory	
Memory for visualization	4MB flash memory	24MB flash memory	
external memory	Micro SD, up to 8 GB	Micro SD, up to 8 GB	

Most important properties at a glance

<h4>S7-Programming</h4> <p>Use existing Siemens-S7-programming tools; either SIMATIC®-Manager or TIA-Portal® in the programming languages LAD, DBD, STL, SCL. Or use existing FB's like for PID in analog operations...</p>	<h4>System boot time 4 seconds</h4> <p>No Windows-firmware means to boot up in less than 4 seconds and primarily: no run time licenses. And also no run-time limitations for any power tags. Therewith today's devices still may be able to update in more than 20 years...</p>
<h4>Know-how-protection</h4> <p>Save your work from illegal copying, save you know-how to sell it more than once. Set really heavy protections by free ServiceStage (Siemens-password functions are still available.)</p>	<h4>Gateway-functionality</h4> <p>Ethernet with TCP, UDP, RFC1006 or Modbus TCP, Profibus-DP V0 Master/Slave, CANopen® or Layer2, free ASCII on RS232 and RS485 and Modbus RTU INSEVIS-S7-PLC - a communication talent</p>



Data to INSEVIS-S7-CPU

Devices with CPU-T have more memory, a higher speed and can drive larger panels with more visualization objects. They fit perfectly for medium and large sized automation solutions.

2 separated Ethernet ports for separated networks or together as an Ethernet switch are onboard. Profinet IO Controller is available as an option. Panel-PLC and Panel-HMIs with these CPUs contain an VNC-server. Panel-PLCs and Compact-PLCs contain a static web-server.



Property	Technical data
OB, FC, FB, DB Local data Depth of nesting	Each 2.048 32kByte (2kByte per block) up to 16 code blocks
Number of inputs and outputs Process image	in each case 4.096 Byte (32.796 Bit) addressable in each case 4.096 Byte (default set is 128 Byte)
Number of memory bytes Number of clock memory	4.096 (remanence adjustable, default set is 0..15) 8 (1 Markerbyte)
Number of timer, counter	in each case 512 (each remanence adjustable, default set is 0)
Real-time clock elapsed hour counter	yes (accumulator-backed hardware clock) 1 (32Bit, resolution 1h)
Program language Program system	STEP 7® - STL, LAD, FBD, S7-SCL, S7-Graph from Siemens SIMATIC® Manager from Siemens or products compatible to it
Operating system Program unit to reference	compatible to S7-300® from Siemens CPU 315-2DP/PN (6ES7 315-2EH14-0AB0 firmware V3.1 Siemens)
Communication	
Serial interfaces (protocols)	COM1: RS 232 (free ASCII) COM2: RS 485 (free ASCII, Modbus-RTU)
Ethernet (protocols)	Ethernet: 10/100 MBit with CP343 functionality (RFC1006, TCP, UDP, Modbus-TCP)
CAN (protocols)	CAN-telegrams (Layer 2), compatible to CANopen® master 10 kBaud ... 1 MBaud
optional interfaces (protocols)	Profinet IO Controller
Periphery access	
Decentral periphery	- INSEVIS- periphery (with automatic configuration via „ConfigStage“) - diverse external periphery families (Modbus RTU/TCP, CAN) - all CANopen® slaves according to DS401 - all Profinet IO-devices

Memory	CPU-T
Working memory (thereof batt.-buffered)	1MB (512 kByte remanent)
Load memory	8MB flash memory
Memory for visualization	48MB flash memory
external memory	Micro SD, up to 8 GB

Remark:

The S7-program data are kept in the flash memory (Flash) and the S7-process data are kept in the battery-buffered RAM (SRAM) and not on the Micro-SD-card. This is for archiving and backup only.

Most important properties at a glance

Usual S7-Programming	2 Ethernet-Ports
Use existing Siemens-S7-programming tools; either SIMATIC®-Manager or TIA-Portal® in the programming languages STL, LAD, FBD, SCL, S7-Graph. Or use existing FB's like for PID in analog operations...	With 2 Ethernet-interfaces configurable as separated ports with each an own IP-address area you can use the PLC as gateway between office / maintenance and machine network and grant an easy service access, or use it as 2 port-switch
VNC- and Web-server	Gateway-functionality
Show and control your panel content 1:1 on mobile devices like tablets or smart phones. Display device identification and I/O status of the PLC by an static web server on a web browser.	Ethernet with TCP, UDP, RFC1006 or Modbus TCP, Profibus-DP V0 Master/Slave, CANopen® or Layer2, free ASCII on RS232 and RS485 and Modbus RTU INSEVIS-S7-PLC - a communication talent



Possible S7-System architectures

Each solution has its own characteristics, where to the solution should be adapted. Customers demands, available space, kind and number of I/Os, demands for communication and - last but not least- the project budget. With INSEVIS all common S7-system architectures can be realized. Always compatible to S7 but always open for your favorite system too. To become a leading technological and economical solution and to stay independent from only one supplier.

S7-Panel-PLC with onboard periphery (decentrally expandable)

The most compact, simplest and economic solution. All in one device, Panel and S7-PLC use a common CPU (with one IP-address) and with free slots for onboard periphery. Always expandable by decentral periphery (INSEVIS- or external periphery).



S7-Panel-PLC with decentrally expandable periphery

In this solution Panel and S7-PLC use a common CPU (with one IP-address) and are expandable by decentral periphery. The most easiest and economic is mostly INSEVIS- periphery blocks – set up the node ID and be ready, but other peripheries are to use as well by multiple interfaces.



Panel with decentral S7-Compact-PLC with onboard periphery (decentrally expandable)

This solution differs to that before in having only a Panel-HMI (with an own IP-address) in the switching cabinets door and an S7-PLC at the DIN-rail (with another IP-address) and with free slots for onboard periphery there. Always expandable by decentral periphery (INSEVIS- or external periphery).

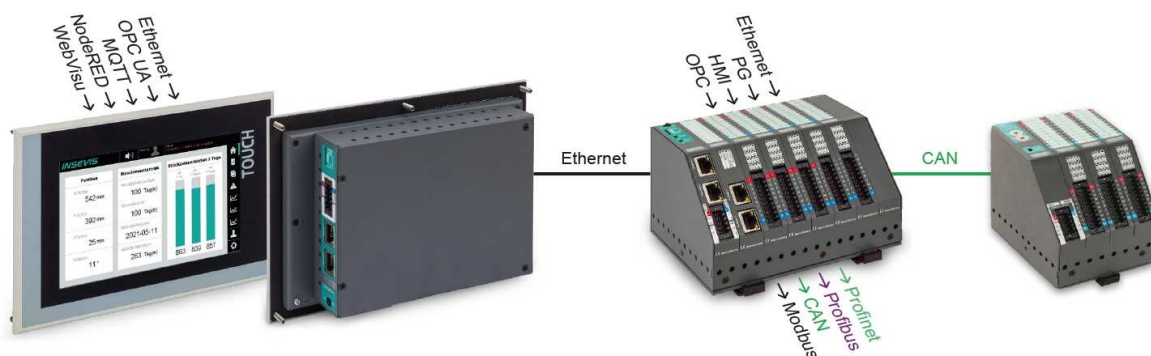



Customized versions of serial products

Every solution has its own characteristics, where to the method of resolution must fit. Customer wishes, space available, number and kind of sensors and actuators, communication requirements and finally but not last: the budget.

Most of the S7-system architectures can be solved easily with INSEVIS products. Always compatible to S7 but also open for other systems to integrate. But some tasks need a special solution what is done best by a customized design.

S7-Panel-PLC and S7-Compact-PLC with customized onboard periphery

A customized product is always an own project with concept, specification, product samples and approval. By our very long experience in this field the customer value is maximum, when customized designs refer to I/O-level (Number and kind of I/Os, connectors, pre processing of data onboard, etc). Than this board is fix, but panel and PLC-boards below stay in standard design (will be updated always). This guarantees a living combination of customers competence (I/Os) and our (panel and PLC) for a sustainable solution.

Based on that experiences INSEVIS offers for cost sensitive serial applications the possibility to create their own periphery module to use it either:

- directly onboard on the rear side of a Panel-PLC and Compact-PLC with CPU-T (Slim version)
- or:
- decentral as DIN-rail module (all CPU versions),

Possibilities for customized periphery modules		
Onboard possible at: - CC301T-x-02 - PC431T-x-02 - PC711T-x-02 - PC1011T-x-02 - PC1561T-x-02		Applicable at: - Onboard periphery (mounted on the PLC) - Decentral periphery (free in dimensions)
Stay standard: S7-PLC-functionality Visualization functionality All interfaces Internal firmware Programming tool Remote visualizations Configuration tool Service tool and -routines		Become customized: Digital inputs 24VDC Counters 5/ 24VDC Digital outputs 24VDC Relay outputs 230VAC Analog inputs U/ I/ RTD Thermocouple/ res. wire strain Analog outputs U/ I Clamps / connectors
	Structure of a customized onboard periphery module in a PC430T, without cover	

INSEVIS involves the customer in the design process, so that 3 cases are possible depending on the customers know-how in electronic design.

Complete service: Development and delivery of a customized module based on a system specification			
INSEVIS part	Customers part	Advantage	Disadvantages
Circuit design and simulation, PCB-layout and simulation, Production, mounting, test	Approval	Short development times No project stress and risk	Development costs incur Production initial costs incur Minimum lot size: 100 pieces
Partly service: Development of a customized module based on a system specification			
INSEVIS part	Customers part	Advantage	Disadvantages
Circuit design and simulation, PCB-layout and simulation	Approval of production data, Production, mounting, test	Probably lower unit costs Improve workload of own production	Development costs incur Minimum lot size: 100 pieces
Consulting service: Supporting a customers development based on a system specification			
INSEVIS part	Customers part	Advantage	Disadvantages
Information about interface design Attendant project consultancy	Circuit design and simulation, PCB-layout and simulation, Production, mounting, test	Know-how stays at customer (for instance data pre processing formulas)	Design responsibility for customer Minimum lot size: 100 pieces





S7-Panel-PLC



INSEVIS-S7-Panel-PLC – Combination of S7-PLC and brilliant panel in a tight space

Controlling, visualization and communication in a narrow spot. The most compact way to automatize – and with INSEVIS the most economic too. Metal front frames with protection class IP65 provide a high quality, S7-programming keep your know-how and do not touch your way of programming with SimaticManager or TIA-Portal from Siemens. Equipped with comprehensive communication channel like Ethernet, Modbus, CAN, RS232 and RS485 and optional Profibus DP resp. Profinet IO Controller. With onboard- and/or decentrally periphery in fine grades. Open for external periphery devices and closed for illegal copy actions. Labeled with customers logo to make INSEVIS- customers inexchangeable.

Product groups

3,5" and 5,7" with S7-CPU-V or-P



High value for beginners already including high-class functions

- PC350V/P (without IOs)
- PC351V/P (fixed IOs)
- PC353V/P (modular IOs)
- PC570V/P (without IOs)
- PC577V/P (modular IOs)

4,3" and 7" with S7-CPU-T



Compact and very fast: the „small ones“ in 16:9 format

- PC430T (no IOs)
- PC431T (fixed IOs)
- PC433T (modular IOs)
- PC710T (no IOs)
- PC711T (fixed IOs)
- PC717T (modular IOs)

10,1" and 15,6" with S7-CPU-T



Allow new project chances: the „large ones“ with CPU-T

- PC1010T (no IOs)
- PC1011T (fixed IOs)
- PC1017T (modular IOs)
- PC1560T (no IOs)
- PC1561T (fixed IOs)
- PC1567T (modular IOs)

Fields of application

- Compact controllers for production data acquisition and OPC- forwarding by S7-communication / active Ethernet,
- Economical connection of different external peripheries, drives, frequency converters and so on into the S7-world,
- Remote data collecting and logging with visualization in combination with other S7-controllers,
- Event display for small switching cabinets, replacement of elements for manual operation,
- Improvement of connectivity and visualization of existing automation solutions,
- Replacement of failed or older C7-controllers and/or OP/TP/MP-panels, what are no more available.



Communication overview

INSEVIS-S7-Panel-PLCs contain versatile possibilities for a connection to diverse peripheries or communication with other devices. Lots of protocols are implemented already, others can be realized with the cost free INSEVIS-S7-SFBs and SFCs by the S7-programmer itself.

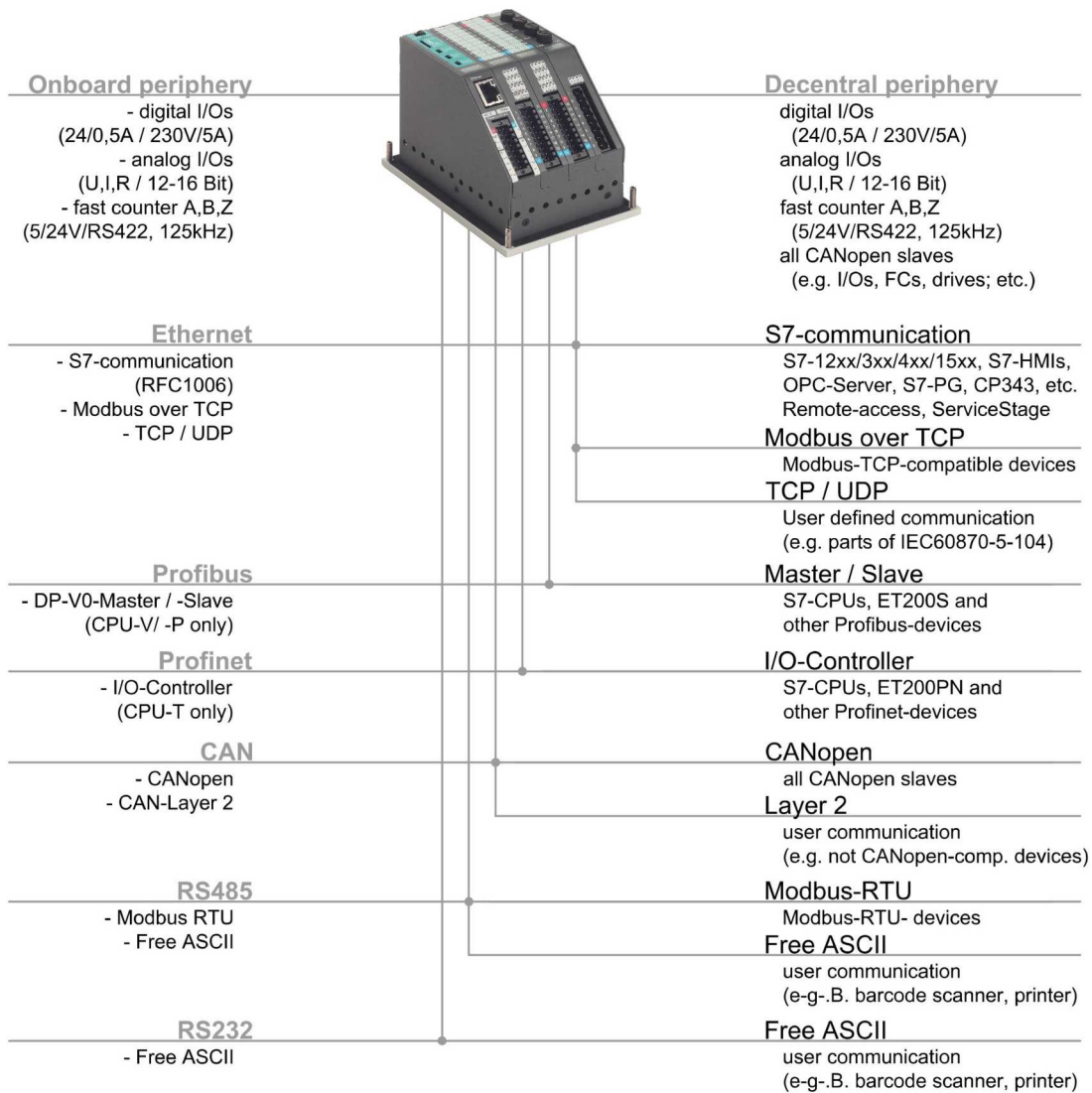

External memory card

Each device has an own slot for an optional Micro-SD-card in the standard FAT32-format. This card is only needed for archiving message data, data from DBs, trend data as well as of data of the recipe management and for backup/restore. While updating the PLC- firmware by this card, the S7-data (program, data, process data, visualization data) will kept untouched - as they were before.

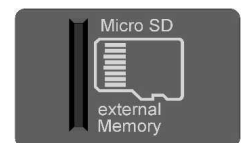

Most important properties at a glance



<p>Usual S7-Programming</p> <p>Use existing Siemens-S7-programming tools; either SIMATIC®-Manager or TIA-Portal® in the programming languages STL, LAD, FBD, SCL, S7-Graph. Or use existing FB's like for PID in analog operations...</p>	<p>Backup & Restore – without PC</p> <p>Easy to backup all data; S7-program, data, process data, visualization data, archive data – password protected as binary to use it in an identical device. This will go on working, where the old device was backed up – no need to have a computer therefore.</p>
<p>Ultra-compact design</p> <p>INSEVIS offers the most compact combination of panel and PLC and onboard periphery worldwide (PC351V/P) and the most thin S7-Touchpanel-PLC with 26mm depth (PC430T). This allows to decrease the space and energy consumption.</p>	<p>Remote access, Web- and VNC- server</p> <p>Use multiple PC-monitors as additional panels by RemoteStage, display and control a 1:1-image by your VNC-Viewer. Check the status of the PLC and of the in- and outputs in a web browser by an integrated static web server.</p>

S7-Panel-PLC

S7-Panel-PLCs with 3,5"-displays

Large jumps for small applications, what need to be realized with low budget. This is the world of the smallest Panel-PLCs of INSEVIS with 320x240 pixel (QVGA) and in 4:3-format. But this smallest PLCs contain the instruction set of a S7-315-2PNDP – with more memory. For some it is the first PLC- application, for others a long wanted solution for long time available 5,7" substitutions.

The abdication of Windows-OS reduces the power consumption (<100mA @ 24V) and the booting time (<3 seconds). Impress your customers by quality and power and keep your own economy. Compact, energy saving and customized labeled with the first device already.

	<p>Series PC350 without onboard periphery slots</p> <p>3,5"-display (320x240 Pixel, 4:3-format, 65.000 colors) with resistive touch Dimension front: 132x96mm, class of tightness: IP65, weight: ca. 450g Range of operation temperature: -20°C...+60°C Periphery decentral expandable by Profibus, CAN, Modbus Voltage supply: 24 (11...30)V DC Current consumption: 60mA (typ.)...200mA (max. with Profibus M/S) Power dissipation: 1,5W (typ.)...4,8W (max. with Profibus M/S) Depth into switching cabinet: 49mm</p>
	<p>Series PC351 with fixed onboard periphery</p> <p>Front, operating temperature range, voltage supply, current consumption, power dissipation like series PC350 – but on rear side with fixed onboard periphery (software configurable): 4 digital in- or outputs 24V / 0,5A (to be configured bitwise by software, as well as counter 10kHz) 2 analog inputs- (± 20 mA, (0)4..20 mA, 0..10 V) or outputs ((0)4..20 mA, 0..10 V) (each channel to be configured by software) Periphery decentral expandable by Profibus, CAN, Modbus Depth into switching cabinet: 49mm</p>
 <p>figure shows onboard periphery (optionally)</p>	<p>Series PC353 with 3 free slots for modular onboard periphery</p> <p>Front and operating temperature range like series PC350 - but on rear side with 3 free slots for INSEVIS periphery onboard: - max. 48 digital inputs (24V) or 18 counter (5V/24V/RS422) - max. 48 digital outputs (24V/0,5A) or 12 relays (230V/3A) - max. 24 analog inputs (U/I/PT) or 12 analog outputs (U/I) - max. 44 current- and 33 voltage measurements by E-Mess-UI Periphery decentral expandable by Profibus, CAN, Modbus Voltage supply: 24 (11...30)V DC Current consumption: 60mA (typ.)...500mA (max. with Profibus M/S and PMs) Power dissipation: 1,5W (typ.)...12W (max. with Profibus M/S and PMs) Depth into switching cabinet: 84mm</p>

Article number	CPU	Ethernet	Modbus	CAN	Serial CP	Profibus	Profinet	Periphery		VNC-server	Web-server	
		S7/TCP/UDP	RTU/TCP	CANopen	RS232/485	DP-M	DP-S	IO-Ctrl.	onboard			decentral
PC350V-0-03	-V	√	√	√	√	-	-	-	-	(√)	-	-
PC350V-DPM-03	-V	√	√	√	√	√	-	-	-	(√)	-	-
PC350V-DPS-03	-V	√	√	√	√	-	√	-	-	(√)	-	-
PC350P-0-03	-P	√	√	√	√	-	-	-	-	(√)	-	-
PC350P-DPM-03	-P	√	√	√	√	√	-	-	-	(√)	-	-
PC350P-DPS-03	-P	√	√	√	√	-	√	-	-	(√)	-	-
PC351V-0-03	-V	√	√	√	√	-	-	-	4dIO/2aIO	(√)	-	-
PC351V-DPM-03	-V	√	√	√	√	√	-	-	4dIO/2aIO	(√)	-	-
PC351V-DPS-03	-V	√	√	√	√	-	√	-	4dIO/2aIO	(√)	-	-
PC351P-0-03	-P	√	√	√	√	-	-	-	4dIO/2aIO	(√)	-	-
PC351P-DPM-03	-P	√	√	√	√	√	-	-	4dIO/2aIO	(√)	-	-
PC351P-DPS-03	-P	√	√	√	√	-	√	-	4dIO/2aIO	(√)	-	-
PC353V-0-03	-V	√	√	√	√	-	-	-	3 slots	(√)	-	-
PC353V-DPM-03	-V	√	√	√	√	√	-	-	3 slots	(√)	-	-
PC353V-DPS-03	-V	√	√	√	√	-	√	-	3 slots	(√)	-	-

Valid list prices on request from your local INSEVIS-distributor.



S7-Panel-PLC

S7-Panel-PLCs with 4,3“-displays

Brilliant, compact, strong and very communicative. And always programmable by common S7-tools from Siemens as SimaticManager and TIA-Portal. For those who need CPU-performance combined with a small panel. As stand-alone device or additional operating panel in an existing S7-network.

With only 44mm depth extremely compact these Panel-PLCs contain 2 separated Ethernet interfaces (S7-communication, TCP, UDP), Modbus (TCP, RTU), CAN (CANopen® and Layer2), RS232 and RS485 (free ASCII) and optional Profinet IO Controller- this is quite a lot.

Special variant with fixed periphery: The PC431T already includes extensive, flexibly configurable onboard periphery on the rear, which can serve many applications and are very compact. Remote CAN or Modbus periphery are available as well.

	<p>Series PC430 without onboard periphery slots</p> <p>4,3“-display (480x272 Pixel, 4:3-format, 65.000 colors) with resistive touch Dimension front: 140x100mm, class of tightness: IP65, weight: ca. 450g Range of operation temperature: -20°C...+60°C Periphery decentral expandable by Profinet, CAN, Modbus Voltage supply: 24 (11...30)V DC Current consumption: 150mA (typ.)...300mA (max. with Profinet) Power dissipation: 3,6W (typ.)...7,2W (max. with Profinet) Depth into switching cabinet: PC430T-PNC-02: 44mm PC430T-0-03: 25mm</p>
 <p>connections downwards</p>	<p>Series PC431 with fixed onboard periphery</p> <p>4,3“-display (480x272 Pixel, 4:3-format, 65.000 colors) with resistive touch Dimension front: 140x100mm, class of tightness: IP65, weight: ca. 600G, Depth 43mm, Range of operation temperature: -20°C...+60°C, Voltage supply: 24 (11...30)V DC Current consumption: 200mA (typ.), Power dissipation: 5W (typ.), Onboard periphery: 12 digital IO, bitwise configurable, thereof 2 PWM- and 2 PushPull outputs 12 digital I, thereof 2 counter up to 1kHz and 2 counter (ABZ) up to 100kHz, 3 analog IO, channelwise configurable as in- or output and for voltage or current, 3 analog I, all configurable as RTD/ U/ I/ TC/ strain gauges Periphery decentral expandable by CAN and Modbus (PC431T-D → digital IOs only)</p>
 <p>figure shows onboard periphery (optionally)</p>	<p>Series PC433 with 3 free slots for modular onboard periphery</p> <p>Front and operating temperature range like series PC430 - but on rear side with 3 (with Profinet 2) free slots for INSEVIS periphery onboard: - max. 48 digital inputs (24V) or 18 counter (5V/24V/RS422) - max. 48 digital outputs (24V/0,5A) or 12 relays (230V/3A) - max. 24 analog inputs (U/I/PT) or 12 analog outputs (U/I) Periphery decentral expandable by Profinet, CAN, Modbus Voltage supply: 24 (11...30)V DC Current consumption: 150mA (typ.)...300mA (max. with Profinet and PMs) Power dissipation: 4W (typ.)...7,5W (max. with Profinet M/S and PMs) Depth into switching cabinet: 89mm</p>

Article no.	CPU	Ethernet	Modbus	CAN	Serial CP	Profibus	Profinet	Periphery		VNC-server	Web-server	
		S7/TCP/UDP	RTU/TCP	CANopen	RS232/485	DP-M	DP-S	IO-Ctrl.	onboard			decentral
PC430T-0-03	-T	2 ✓	✓	✓	✓	-	-	-	-	(✓)	✓	✓
PC430T-PNC-02	-T	2 ✓	✓	✓	✓	-	-	✓	-	(✓)	✓	✓
PC431T-0-02	-T	2 ✓	✓	✓	✓	-	-	-	fixed	(✓)	✓	✓
PC431T-D-02	-T	2 ✓	✓	✓	✓	-	-	-	fixed	(✓)	✓	✓
PC433T-0-02	-T	2 ✓	✓	✓	✓	-	-	-	3 slots	(✓)	✓	✓
PC433T-PNC-02	-T	2 ✓	✓	✓	✓	-	-	✓	2 slots	(✓)	✓	✓

Valid list prices on request from your local INSEVIS-distributor.



S7-Panel-PLC

S7-Panel-PLCs with 5,7"-displays

For those, who miss this 5,7" (6") panels from Siemens, these devices will be a good solution with long termed availability. But there is not only a panel, a PLC is integrated too! And this is a very strong PLC with the instruction set of a S7-315-2PN DP but more memory and a number of interfaces.

Often used as basic model or as additional control panel in combination to existing S7-PLCs. The large memory and the number of interfaces favor this part for an use as data logger or gateway with data preprocessing.

	<p>Series PC570 without onboard periphery slots</p> <p>5,7"-display (320x240 Pixel, 4:3-format, 65.000 colors) with resistive touch Dimension front: 182x140mm, class of tightness: IP65, weight: ca. 600g Range of operation temperature: -20°C...+60°C Periphery decentral expandable by Profibus, CAN, Modbus Voltage supply: 24 (11...30)V DC Current consumption: 100mA (typ.)...170mA (max. with Profibus M/S) Power dissipation: 2,4W (typ.)...4,1W (max. with Profibus M/S) Depth into switching cabinet: 49mm</p>
<p>figure shows onboard periphery (optionally)</p>	<p>Series PC577 with 7 free slots for modular onboard periphery</p> <p>Front and operating temperature range like series PC570 - but on rear side with 7 free slots for INSEVIS periphery onboard:</p> <ul style="list-style-type: none"> - max. 112 digital inputs (24V) or 42 counter (5V/24V/RS422) - max. 112 digital outputs (24V/0,5A) or 28 relays (230V/3A) - max. 56 analog inputs (U/I/PT) or 28 analog outputs (U/I) - max. 56 current- and 21 voltage measurements by E-Mess-UI <p>Periphery decentral expandable by Profibus, CAN, Modbus Voltage supply: 24 (11...30)V DC, Current consumption: 60mA (typ.)...500mA (max. with Profibus M/S and PMs) Power dissipation: 1,5W (typ.)...12W (max. with Profibus M/S and PMs) Depth into switching cabinet: 95mm</p>

Article no.	CPU	Ethernet	Modbus	CAN	Serial CP	Profibus		Profinet	Periphery		VNC-server	Web-server
		S7/TCP/UDP	RTU/TCP	CANopen	RS232/485	DP-M	DP-S	IO-Ctrl.	onboard	decentral		
PC570V-0-03	-V	√	√	√	√	-	-	-	-	(√)	-	-
PC570V-DPM-03	-V	√	√	√	√	√	-	-	-	(√)	-	-
PC570V-DPS-03	-V	√	√	√	√	-	√	-	-	(√)	-	-
PC570P-0-03	-P	√	√	√	√	-	-	-	-	(√)	-	-
PC570P-DPM-03	-P	√	√	√	√	√	-	-	-	(√)	-	-
PC570P-DPS-03	-P	√	√	√	√	-	√	-	-	(√)	-	-
PC577V-0-03	-V	√	√	√	√	-	-	-	7 slots	(√)	-	-
PC577V-DPM-03	-V	√	√	√	√	√	-	-	7 slots	(√)	-	-
PC577V-DPS-03	-V	√	√	√	√	-	√	-	7 slots	(√)	-	-
PC577P-0-03	-P	√	√	√	√	-	-	-	7 slots	(√)	-	-
PC577P-DPM-03	-P	√	√	√	√	√	-	-	7 slots	(√)	-	-
PC577P-DPS-03	-P	√	√	√	√	-	√	-	7 slots	(√)	-	-

Valid list prices on request from your local INSEVIS-distributor.





S7-Panel-PLC

S7-Panel-PLCs with 7"-displays

For those, who wanted to show a little more than basic objects on his 16:9-panels, this was a quite expensive deal until now. With these 7"-Panel-PLCs of INSEVIS these times are gone. These medium sized panels and its powerful integrated S7-CPU with the operation code of an S7-315-2PNDP allow projects with high class functionality together with a high own margin.

The visualization projects and cut outs for all these INSEVIS-7"-Panel-PLCs are identical – to get an own graduated product line with no extra efforts. Of course branded with your logo an article-numbers on the rear side.

Special variant with fixed periphery: The PC711T already includes extensive, flexibly configurable onboard periphery on the rear, which can serve many applications and are very compact. Remote CAN or Modbus periphery are available as well.

	<p>Series PC710 without onboard periphery slots</p> <p>7"-display (800x480 Pixel, 4:3-format, 65.000 colors) with resistive touch Dimension front: 222x147mm, class of tightness: IP65, weight: ca. 700g, Range of operation temperature: -20°C...+60°C, Voltage supply: 24 (11...30)V DC Depth into switching cabinet: 45mm, Voltage supply: 24 (11...30)V DC, Current consumption: 250mA (typ.)...350mA (max. with Profinet) Power dissipation: 5W (typ.)...8,5W (max. with Profinet) Periphery decentral expandable by Profinet, CAN, Modbus OEM / customized periphery possible at PC710T-0</p>
 <p>I/O connections seen from the rear on the right</p>	<p>Series PC711 with fixed onboard periphery</p> <p>7"-display (800x480 Pixel, 4:3-format, 65.000 colors) with resistive touch Dimension front: 222x147mm, class of tightness: IP65, weight: ca. 850g, Range of operation temperature: -20°C...+60°C, Voltage supply: 24 (11...30)V DC Current consumption: 300mA (typ.), Power dissipation: 6W (typ.), Depth into switching cabinet: 45mm, Onboard periphery: 12 digital IO, bitwise configurable, thereof 2 PWM- and 2 PushPull outputs 12 digital I, thereof 2 counter up to 1kHz and 2 counter (ABZ) up to 100kHz, 3 analog IO, channelwise configurable as in- or output and for voltage or current, 3 analog I, all configurable as RTD/ U/ I/ TC/ strain gauges Periphery decentral expandable by CAN and Modbus (PC711T-D → digital IOs only)</p>
 <p>figure shows onboard periphery (optionally)</p>	<p>Series PC717 with 7 free slots for modular onboard periphery</p> <p>Front and operating temperature range like series PC710T- but on rear side 7 (with Profinet 6) free slots for INSEVIS periphery onboard: - max. 112 digital inputs (24V) or 42 counter (5V/24V/RS422) - max. 112 digital outputs (24V/0,5A) or 28 relays (230V/3A) - max. 56 analog inputs (U/I/PT) or 28 analog outputs (U/I) Periphery decentral expandable by Profinet, CAN, Modbus Voltage supply: 24 (11...30)V DC Current consumption: 200mA (typ.)...1300mA (max. with Profinet and PMs) Power dissipation: 4,8W (typ.)...31,2W (max. with Profinet and PMs) Depth into switching cabinet: 95mm,</p>

Article no.	CPU	Ethernet		Modbus		CAN		Serieller CP		Profibus		Profinet		Periphery		VNC-server	Web-server
		S7/TCP/UDP	RTU/TCP	CANopen	RS232/485	DP-M	DP-S	IO-Ctrl.	onboard	decentral							
PC710T-0-03	-T	2 ✓	✓	✓	✓	-	-	-	-	-	-	-	(✓)	✓	✓		
PC710T-PNC-02	-T	2 ✓	✓	✓	✓	-	-	✓	-	-	✓	-	(✓)	✓	✓		
PC711T-0-02	-T	2 ✓	✓	✓	✓	-	-	✓	-	-	✓	fixed	(✓)	✓	✓		
PC711T-D-02	-T	2 ✓	✓	✓	✓	-	-	✓	-	-	✓	fixed	(✓)	✓	✓		
PC717T-0-02	-T	2 ✓	✓	✓	✓	-	-	-	-	-	-	7 slots	(✓)	✓	✓		
PC717T-PNC-02	-T	2 ✓	✓	✓	✓	-	-	✓	-	-	✓	6 slots	(✓)	✓	✓		

Valid list prices on request from your local INSEVIS-distributor.



S7-Panel-PLC

S7-Panel-PLCs with 10"-displays

The shooting stars for 16:9-Panels in medium sizes offers chances because of its unique price/performance ratio in the S7-world. These devices will be a large showcase for your application. They do not only contain a brilliant touch panel, they provide a very strong PLC with the instruction set of a S7-315-2PNDP too. And not enough: a number of interfaces are integrated as well.

It is a combination of the high quality impression by the metal frame, the fast booting and page-turning times and the chance to label these parts with the first piece, what makes it so successfully. And of course – no runtime limitations of the visualization.

Special variant with fixed periphery: The PC1011T already includes extensive, flexibly configurable onboard periphery on the rear, which can serve many applications and are very compact. Remote CAN or Modbus periphery are available as well.

	<p>Series PC1010 without onboard periphery slots</p> <p>10,1"-display (1024x600 Pixel, 16:9-format, 65.000 colors) with resistive touch Dimension front: 286x188mm (like PC1000), class of tightness: IP65, weight: ca. 1000G, Depth into switching cabinet: 48mm Range of operation temperature: -20°C...+60°C, Voltage supply: 24 (11...30)V DC, Current consumption: 350mA (typ.)...500mA (max. with Profinet) Power dissipation: 8,5W (typ.)...12W (max. with Profinet) Periphery decentral expandable by Profinet, CAN, Modbus</p>
<p>I/O connections seen from the rear on the right</p>	<p>Series PC1011 with fixed onboard periphery</p> <p>10,1"-display (1024x600 Pixel, 16:9-format, 65.000 colors) with resistive touch Dimension front: 286x188mm (like PC1000), class of tightness: IP65, weight: ca. 1100g Range of operation temperature: -20°C...+60°C, Voltage supply: 24 (11...30)V DC Current consumption: 400mA (typ.), Power dissipation: 9,5W (typ.), Depth into switching cabinet: 45mm, Onboard periphery: 12 digital IO, bitwise configurable, thereof 2 PWM- and 2 PushPull outputs 12 digital I, thereof 2 counter up to 1kHz and 2 counter (ABZ) up to 100kHz, 3 analog IO, channelwise configurable as in- or output and for voltage or current, 3 analog I, all configurable as RTD/ U/ I/ TC/ strain gauges Periphery decentral expandable by CAN and Modbus (PC1011T-D → digital IOs only)</p>
<p>figure shows onboard periphery (optionally)</p>	<p>Series PC1017 with 7 free slots for modular onboard periphery</p> <p>Front and operating temperature range like series PC1010- but on rear side with 7 (with Profinet 6) free slots for INSEVIS periphery onboard: - max. 112 digital inputs (24V) or 42 counter (5V/24V/RS422) - max. 112 digital outputs (24V/0,5A) or 28 relays (230V/3A) - max. 56 analog inputs (U/I/PT) or 28 analog outputs (U/I) Periphery decentral expandable by Profinet, CAN, Modbus Voltage supply: 24 (11...30)V DC Current consumption: 200mA (typ.)...1300mA (max. with Profinet and PMs) Power dissipation: 4,8W (typ.)...31,2W (max. with Profinet and PMs) Depth into switching cabinet: 98mm</p>

Article no.	CPU	Ethernet	Modbus	CAN	Serial CP	Profibus	Profinet	Periphery		VNC-server	Web-server	
		S7/TCP/UDP	RTU/TCP	CANopen	RS232/485	DP-M	DP-S	IO-Ctrl.	onboard			decentral
PC1010T-0-03	-T	2 ✓	✓	✓	✓	-	-	-	-	(✓)	✓	✓
PC1010T-PNC-02	-T	2 ✓	✓	✓	✓	-	-	✓	-	(✓)	✓	✓
PC1011T-0-02	-T	2 ✓	✓	✓	✓	-	-	✓	fixed	(✓)	✓	✓
PC1011T-D-02	-T	2 ✓	✓	✓	✓	-	-	✓	fixed	(✓)	✓	✓
PC1017T-0-02	-T	2 ✓	✓	✓	✓	-	-	-	7 slots	(✓)	✓	✓
PC1017T-PNC-02	-T	2 ✓	✓	✓	✓	-	-	✓	6 slots	(✓)	✓	✓

Valid list prices on request from your local INSEVIS-distributor.





S7-Panel-PLCs with 15,6“-displays

These devices set free your creative sense and are a real low-budget substitution for industrial PCs with expensive visualization- RunTimes. Not to forget: they do not contain any Windows and even in 20 years there will be no performance problem when updating these devices.

These S7-Panel-PLCs with large diagonals push forward into new application areas: Instead of using expensive IPC- solutions with tag based soft-visualizations these devices can bring high quality, long term availability and economy in this field of application. If it is a firmware update or new user program – you can do it by Ethernet or by a simple Micro-SD-card.

Special variant with fixed periphery: The PC1561T already includes extensive, flexibly configurable onboard periphery on the rear, which can serve many applications and are very compact. Remote CAN or Modbus periphery are available as well.

	<p>Series PC1560 without onboard periphery slots</p> <p>15,6“-display (1366x768 Pixel, 16:9-Format, 65.000 colors) with resistive touch Dimension front: 410x250, class of tightness: IP65, weight: ca. 1400g Range of operation temperature: 0°C...+50°C, Depth into switching cabinet: 54mm Voltage supply: 24 (11..30)V DC Current consumption: 500mA (typ.)...650mA (max. with Profinet) Power dissipation: 12W (typ.)...15W (max. with Profinet) Periphery decentral expandable by Profinet, CAN, Modbus</p>
 <p>I/O connections seen from the rear on the right</p>	<p>Series PC1561 with fixed onboard periphery</p> <p>15,6“-display (1366x768 Pixel, 16:9-Format, 65.000 colors) with resistive touch Dimension front: 410x250, class of tightness: IP65, weight: ca. 1550g Range of operation temperature: 0°C...+50°C, Voltage supply: 24 (11...30)V DC Current consumption: 550mA (typ.), Power dissipation: 13W (typ.), Depth into switching cabinet: 45mm, Onboard periphery: 12 digital IO, bitwise configurable, thereof 2 PWM- and 2 PushPull outputs 12 digital I, thereof 2 counter up to 1kHz and 2 counter (ABZ) up to 100kHz, 3 analog IO, channelwise configurable as in- or output and for voltage or current, 3 analog I, all configurable as RTD/ U/ I/ TC/ strain gauges Periphery decentral expandable by CAN and Modbus (PC1561T-D → digital IOs only)</p>
 <p>figure shows onboard periphery (optionally)</p>	<p>Series PC1567 with 7 free slots for modular onboard periphery</p> <p>Front and operating temperature range like series PC1560T- but on rear side with 7 (with Profinet 6) free slots for INSEVIS periphery onboard: - max. 112 digital inputs (24V) or 42 counter (5V/24V/RS422) - max. 112 digital outputs (24V/0,5A) or 28 relays (230V/3A) - max. 56 analog inputs (U/I/PT) or 28 analog outputs (U/I) Periphery decentral expandable by Profinet, CAN, Modbus Voltage supply: 24 (11..30)V DC Current consumption: 500mA (typ.)...1500mA (max. with Profinet and PMs) Power dissipation: 12W (typ.)...36W (max. with Profinet and PMs) Depth into switching cabinet: 104mm</p>

Article no.	CPU	Ethernet	Modbus	CAN	Serieller CP	Profibus	Profinet	Periphery		VNC-	VNC-	
		S7/TCP/UDP	RTU/TCP	CANopen	RS232/485	DP-M	DP-S	IO-Ctrl.	onboard	decentral	server	server
PC1560T-0-03	-T	2 ✓	✓	✓	✓	-	-	-	-	(✓)	✓	✓
PC1560T-PNC-02	-T	2 ✓	✓	✓	✓	-	-	✓	-	(✓)	✓	✓
PC1561T-0-02	-T	2 ✓	✓	✓	✓	-	-	-	fixed	(✓)	✓	✓
PC1561T-D-02	-T	2 ✓	✓	✓	✓	-	-	-	fixed	(✓)	✓	✓
PC1567T-0-02	-T	2 ✓	✓	✓	✓	-	-	-	7 slots	(✓)	✓	✓
PC1567T-PNC-02	-T	2 ✓	✓	✓	✓	-	-	✓	6 slots	(✓)	✓	✓





Valid list prices on request from your local INSEVIS-distributor.



Accessories for S7-Panel-PLCs

There are available pin marked removable connectors either with lift arms or with bolt flanges to connect INSEVIS devices. This allows a explicit positioning of each pin to the signals and makes the wiring easier. The wire-contact is done by maintenance free cage-clamps for max. 1,5mm² cross sections without wire end sleeves.

A mounting set with grounding terminal is part of every delivery. If periphery modules are ordered, they will be mounted for free at the INSEVIS production together with the referring rear foil, standard inserting and signal stripes.

Figure accessories	Accessories	Article no.
Connectors  E-CONS16 (pin marked connectors for max. 1,5mm ² cross sections)	For devices with CPU V/P: Connector 2x8pin, bolt flanges (mechanically compatible replacement for discontinued E-CON16) Pin-Numbers are printed on the sides. Adapter for Profibus SUB-D9	E-CONS16-00 E-AD-DP12-00
 E-CONS10 (pin marked connectors for max. 1,5mm ² cross sections)	For devices with CPU T: Connector 2x5pin, bolt flanges (mechanically compatible replacement for discontinued E-CON10) Pin-Numbers are printed on the sides.	E-CONS10-00
 E-CON09 (connector for max. 1,5mm ² cross sections)	For for PC351V/P (periphery) only: Connector 2x4pin	E-CON09-00
 E-CON34 E-CONS34 (pin marked connector for max. 1,5mm ² cross sections)	For PC431T/ 711T/ 1011T/ 1561T (periphery) only: Connector 2x17pin, lift & lock arms or Connector 2x17pin, bolt flanges	E-CON34-00 or E-CONS34-00
External memory Hint: S7-program runs without these cards, these parts are used for archiving / recipes / updating only	 Micro SD-card 2GB (external memory) Micro SD-card 4GB (external memory) Micro SD-card 8GB (external memory)	E-MSD2-00 E-MSD4-00 E-MSD8-00
Customized labeling Hint: 1) Single fix costs only, no run-time costs per single PLC	OEM-firmware with integrated customer logo Inserting stripes with customer logo (rear) (for all devices with/without periphery onboard)	SW-BS-OEM ¹⁾ on request
Software Hint: 2) Company license, no run-time costs per single PC 3) Maintenance license Software available for free download at INSEVIS web sites	VisuStage, ConfigStage, RemoteStage, ServiceStage VisuStage full version company license VisuStage 1 year maintenance license VisuStage 3 year maintenance license	- SW-VS ²⁾ SW-VSW ³⁾ SW-VSW3 ³⁾
Spare parts Hint: A mounting set with grounding terminal is part of every delivery	Additional mounting set with grounding terminal for 3,5" and 4,3"-devices Additional mounting set with grounding terminal for 5,7" and 7"-devices Additional mounting set with grounding terminal for 10,1"-devices Additional mounting set with grounding terminal for 15,6"-devices	E-MNT35-00 E-MNT57-00 E-MNT101-00 E-MNT156-00
Part of every delivery	mounting set with grounding terminal technical data sheet	none

Stainless steel front plates, attached parts, customized designs, valid list prices on request from your local INSEVIS-distributor.



S7-Compact-PLC



INSEVIS-S7-Compact-PLC – DIN-rail controllers with onboard advance

These S7-Compact-PLCs in a metal cover contain beside its S7-CPU with huge memory size and lots of communication interfaces a permanently expanded range of fine graded periphery modules, designed for slim spaces and short cable runs it fits perfectly to any mounting plate. Either as S7-to-anywhere-gateway or for onboard periphery applications. Always with wide temperature range from -20°C...+60°C and on demand labeled with customers logo and article-number. Use the lots of onboard interfaces for your preferred external periphery or realize expensive protocols with cost free function blocks from INSEVIS. Stay independent and increase your profit to defend your market position. But always keep on using a high quality level.

Product groups

without periphery slots with S7-CPU-V or-T



Enormous number of interfaces in a very thin metal cover...

- CC300V (without IOs)
- CC300T (without IOs)
- CC301T (fixed IOs)

with 3 periphery slots with S7-CPU-V or-T



Only 82mm wide but enough PLC-power for lots of solutions...

- CC303V (modular IOs)
- CC303T (modular IOs)

with 7 periphery slots with S7-CPU-V or-T



For up to 112 digital or 70 analog signals onboard...

- CC307V (modular IOs)
- CC307T (modular IOs)

with 11 periphery slots with S7-CPU-V or-T



If there must be some more I/Os to be processed...

- CC311V (modular IOs)
- CC311T (modular IOs)

Fields of application

- Compact controllers for production data acquisition and OPC forwarding by S7-communication / active Ethernet,
- Economical connection of different external peripheries, drives, frequency converters and so on into the S7-world,
- Remote data collecting and logging in combination with other S7-controllers,
- Improvement of connectivity of existing automation solutions,
- S7-programmable gateway with preprocessing of data



Communication overview

INSEVIS-S7-Compact-PLCs contain versatile possibilities to connect diverse peripherals or to communicate with other devices. Lots of protocols are implemented already, others can be realized with the cost free INSEVIS-S7-SFBs and SFCs by the S7-programmer itself.

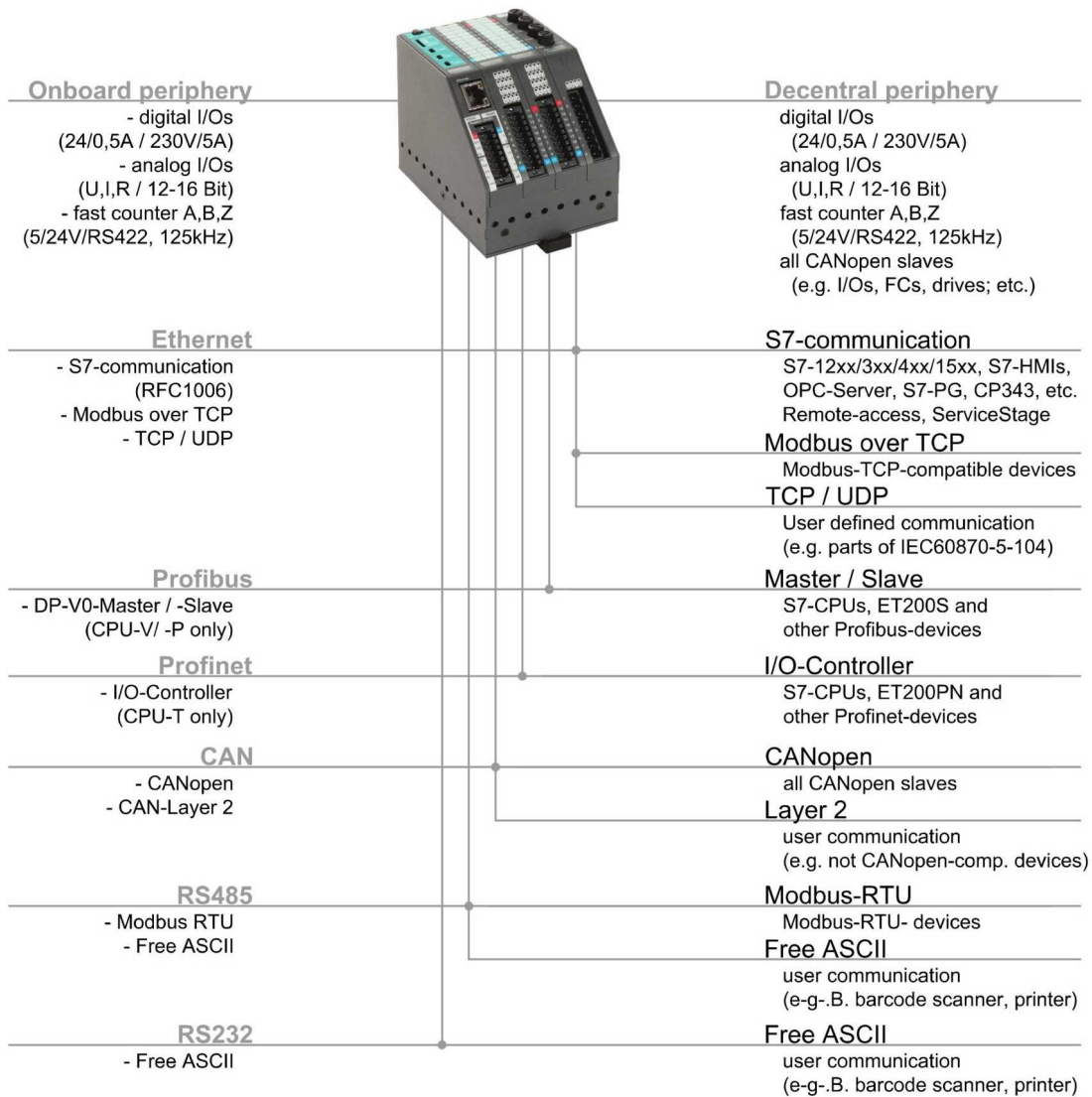

External memory card

Each device has an own slot for an optional Micro-SD-card in the standard FAT32-format. This card is only needed for archiving data from DBs and for backup/restore. While updating the PLC firmware by this card, the S7-program and process data will kept untouched - as they were before.

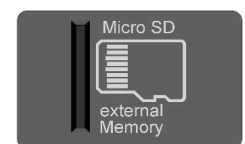

Most important properties at a glance

Usual S7-Programming Use existing Siemens-S7-programming tools; either SIMATIC®-Manager or TIA-Portal® in the programming languages STL, LAD, FBD, SCL, S7-Graph. Or use existing FB's like for PID in analog operations...	Free firmware updates for a lifetime Every device gets new firmware free for a lifetime. Use new features to expand the benefit of your solution. Update it by software or by a single Micro-SD-card without PC and with keeping all your S7-program and process data
Backup & Restore – without PC Easy to backup all data; S7-program, data, process data, visualization data, archive data – password protected as binary to use it in an identical device. This will go on working, where the old device was backed up – no need to have a computer therefore.	Gateway-functionality Ethernet with TCP, UDP, RFC1006 or Modbus TCP, Profibus-DP V0 Master/Slave, CANopen® or Layer2, free ASCII on RS232 and RS485 and Modbus RTU INSEVIS-S7-PLC - a communication talent

S7-Compact-PLC

S7-Compact-PLCs ultra slim

These S7-PLCs for 35mm-DIN-rail are suitable for an economical controlling and communication with S7-programming. Lots of external Peripherals can be connected very simple by integrated interfaces. CC300V/T as data logger or protocol converter - these smallest S7-CPU's V/T are less than 50mm wide and built into a metal cover for rough environments. Every PLC and periphery is available with customized logos from the 1st piece, what shows your automation competence. The CC301T already includes extensive, flexibly configurable onboard periphery on the rear, which can serve many applications and are very compact. Remote CAN or Modbus periphery are available as well.



Series CC300 without onboard periphery slots

Weight: ca. 500g, Range of operation temperature: -20°C...+60°C
 Decentral expandable by CAN, Modbus, Profibus (CPU-V), Profinet (CPU-T)
 Voltage supply: 24 (11...30)V DC

CC300V: Current consumption: 50mA (typ.)...120mA (max. with Profibus M/S)
 Power dissipation: 1,2W (typ.)...2,9W (max. with Profibus M/S)

CC300-T: Current consumption: 150mA (typ.)...300mA (max. with Profinet)
 Power dissipation: 3,6W (typ.)...7,2W (max. with Profinet)

CC301T 12 digital IO, bitwise configurable, thereof 2 PWM- and 2 PushPull outputs
 12 digital I, thereof 2 counter up to 1kHz and 2 counter (ABZ) up to 100kHz,
 3 analog IO, channelwise configurable as in- or output and for voltage/curr.,
 3 analog I, all configurable as RTD/ U/ I/ TC/ strain gauges
 CC301T-D → digital IOs only

Article no.	CPU	Ethernet		Modbus		CAN		Serial CP		Profibus		Profinet		Periphery		Web-server
		S7/TCP/UDP	RTU/TCP	CANopen	RS232+485	DP-M	DP-S	IO-Controller	onboard	decentral						
CC300V-0-03	-V	√	√	√	√	-	-	-	-	-	-	-	(√)	-		
CC300V-DPM-03	-V	√	√	√	√	√	-	-	-	-	-	-	(√)	-		
CC300V-DPS-03	-V	√	√	√	√	-	√	-	-	-	-	-	(√)	-		
CC300T-0-03	-T	2 √	√	√	√	-	-	-	-	-	-	-	(√)	√		
CC300T-PNC-02	-T	2 √	√	√	√	-	-	√	-	-	-	-	(√)	√		
CC301T-0-02	-T	2 √	√	√	√	-	-	-	-	-	-	fixed	(√)	√		
CC301T-D-02	-T	2 √	√	√	√	-	-	-	-	-	-	fixed	(√)	√		

S7-Compact-PLCs with 3 periphery slots 82mm wide

The CC303V/T devices contain beside all the CC300V/T-properties 3 free onboard periphery slots for INSEVIS-periphery modules. This allows an economical solution in the smallest switching cabinet already.

There can be made easy visualizations by our VisuStage for any PC-monitor resolutions. These can be used with the cost free RemoteStage for a free remote display to visualize and control the Compact PLC. Completely free of charge.

figure shows onboard periphery (optionally)



Series CC303 with 3 free slots for modular onboard periphery

Dimensions: 82 x 116,5 x 92mm, Weight: ca. 400g
 Range of operation temperature: -20°C...+60°C

with 3 (with Profinet 2) free slots for INSEVIS periphery onboard:
 - max. 48 digital inputs (24V) or 18 counter (5V/24V/RS422)
 - max. 48 digital outputs (24V/0,5A) or 12 relays (230V/3A)
 - max. 24 analog inputs (U/I/PT) or 12 analog outputs (U/I)
 - max. 12 current- and 9 voltage measurements by E-Mess-UI (only CPU-V)
 Periphery decentral expandable by Profibus (CPU-V) Profinet (CPU-T), CAN, Modbus

Voltage supply: 24 (11...30)V DC

CPU-V: Current consumption: 50mA (typ.)...500mA (max. with Profibus M/S and PMs)
 Power dissipation: 1,2W (typ.)...12W (max. with Profibus M/S and PMs)

CPU-T: Current consumption: 150mA (typ.)...700mA (max. with Profinet and PMs)
 Power dissipation: 3,6W (typ.)...16,8W (max. with Profinet and PMs)

Article no.	CPU	Ethernet		Modbus		CAN		Serial CP		Profibus		Profinet		Periphery		Web-server
		S7/TCP/UDP	RTU/TCP	CANopen	RS232+485	DP-M	DP-S	IO-Controller	onboard	decentral						
CC303V-0-03	-V	√	√	√	√	-	-	-	-	-	-	3 slots	(√)	-		
CC303V-DPM-03	-V	√	√	√	√	√	-	-	-	-	-	3 slots	(√)	-		
CC303V-DPS-03	-V	√	√	√	√	-	√	-	-	-	-	3 slots	(√)	-		
CC303T-0-02	-T	2 √	√	√	√	-	-	-	-	-	-	3 slots	(√)	√		
CC303T-PNC-02	-T	2 √	√	√	√	-	-	√	-	-	-	2 slots	(√)	√		

Valid list prices on request from your local INSEVIS-distributor.



S7-Compact-PLC

S7-Compact-PLCs with 7 periphery slots 161mm wide

The CC307V/T devices contain 4 more onboard-periphery slots as the CC303V/T and are the most sold INSEVIS S7-Compact-PLCs. Often the last slots are left as reserve space.

Every PLC and periphery is available with customized logos from the 1st piece, what increases the automation competence of the customer by far. And the metal case allows an application in rough environments.

figure shows onboard periphery (optionally)

Series CC307 with 7 free slots for modular onboard periphery

Dimensions: 161 x 116,5 x 98mm, Weight: ca. 600g
 Range of operation temperature: -20°C...+60°C
 with 7 (with Profinet 6) free slots for INSEVIS periphery onboard:
 - max. 112 digital inputs (24V) or 42 counter (5V/24V/RS422)
 - max. 112 digital outputs (24V/0,5A) or 28 relays (230V/3A)
 - max. 56 analog inputs (U/I/PT) or 28 analog outputs (U/I)
 - max. 28 current- and 21 voltage measurements by E-Mess-UI (only CPU-V)
 Periphery decentral expandable by Profibus (CPU-V) Profinet (CPU-T), CAN, Modbus
 Voltage supply: 24 (11...30)V DC
 CPU-V: Current consumption: 50mA (typ.)...1000mA (max. with Profibus M/S and PMs)
 Power dissipation: 1,2W (typ.)...24W (max. with Profibus M/S and PMs)
 CPU-T: Current consumption: 150mA (typ.)...1200mA (max. with Profinet and PMs)
 Power dissipation: 3,6W (typ.)...28,8W (max. with Profinet and PMs)

Article no.	CPU	Ethernet	Modbus	CAN	Serial CP	Profibus		Profinet	Periphery		Web-server
		S7/TCP/UDP	RTU/TCP	CANopen	RS232+485	DP-M	DP-S	IO-Controller	onboard	decentral	
CC307V-0-03	-V	√	√	√	√	-	-	-	7 slots	(√)	-
CC307V-DPM-03	-V	√	√	√	√	√	-	-	7 slots	(√)	-
CC307V-DPS-03	-V	√	√	√	√	-	√	-	7 slots	(√)	-
CC307T-0-02	-T	2 √	√	√	√	-	-	-	7 slots	(√)	√
CC307T-PNC-02	-T	2 √	√	√	√	-	-	√	6 slots	(√)	√

Valid list prices on request from your local INSEVIS-distributor.

S7-Compact-PLCs with 11 periphery slots 240mm wide

The CC311V/T devices contain again 4 more onboard-periphery slots as the CC307V/T and is perfect suitable for collecting more I/O-data from field area. It is no problem to connect a panel with RFC1006 / S7-communication to any of the CC3xxV/T -CPUs.

If this is not enough it can be expanded via multiple communication interfaces easily by the decentral periphery of INSEVIS or other vendors – thereby you keep on staying independent.

figure shows onboard periphery (optionally)

Series CC311 with 11 free slots for modular onboard periphery

Dimensions: 240 x 116,5 x 98mm, Weight: ca. 800g
 Range of operation temperature: -20°C...+60°C
 with 11 (with Profinet 10) free slots for INSEVIS periphery onboard:
 - max. 176 digital inputs (24V) or 66 counter (5V/24V/RS422)
 - max. 176 digital outputs (24V/0,5A) or 44 relays (230V/3A)
 - max. 88 analog inputs (U/I/PT) or 44 analog outputs (U/I)
 - max. 44 current- and 33 voltage measurements by E-Mess-UI (only CPU-V)
 Periphery decentral expandable by Profibus (CPU-V) Profinet (CPU-T), CAN, Modbus
 Voltage supply: 24 (11...30)V DC
 CPU-V: Current consumption: 50mA (typ.)...1500mA (max. with Profibus M/S and PMs)
 Power dissipation: 1,2W (typ.)...36W (max. with Profibus M/S and Pms)
 CPU-T: Current consumption: 150mA (typ.)...1700mA (max. with Profinet and PMs)
 Power dissipation: 3,6W (typ.)...40,8W (max. with Profinet and PMs)

Article no.	CPU	Ethernet	Modbus	CAN	Serial CP	Profibus		Profinet	Periphery		Web-server
		S7/TCP/UDP	RTU/TCP	CANopen	RS232+485	DP-M	DP-S	IO-Controller	onboard	decentral	
CC311V-0-03	-V	√	√	√	√	-	-	-	11 Slots	(√)	-
CC311V-DPM-03	-V	√	√	√	√	√	-	-	11 Slots	(√)	-
CC311V-DPS-03	-V	√	√	√	√	-	√	-	11 Slots	(√)	-
CC311T-0-02	-T	2 √	√	√	√	-	-	-	11 Slots	(√)	√
CC311T-PNC-02	-T	2 √	√	√	√	-	-	√	10 Slots	(√)	√





Valid list prices on request from your local INSEVIS-distributor.



Accessories for S7-Compact-PLC

There are available pin marked removable connectors either with lift arms or with bolt flanges to connect INSEVIS-devices. This allows a explicit positioning of each pin to the signals and makes the wiring easier. The wire-contact is done by maintenance free cage-clamps for max. 1,5mm² cross sections without wire end sleeves.

A mounting set with grounding terminal is part of every delivery. If periphery modules are ordered, they will be mounted for free at the INSEVIS production together with the referring rear foil, standard inserting and signal stripes.

Figure accessories	Accessories	Article no.
<p>Connectors</p>  <p>E-CONS16 (pin marked connectors for max. 1,5mm² cross sections)</p>	<p>For devices with CPU V/P: Connector 2x8pin, bolt flanges (mechanically compatible replacement for discontinued E-CON16) Pin-Numbers are printed on the sides.</p> <p>Adapter for Profibus SUB-D9</p>	<p>E-CONS16-00</p> <p>E-AD-DP12-00</p>
 <p>E-CONS10 (pin marked connectors for max. 1,5mm² cross sections)</p>	<p>For devices with CPU T: Connector 2x5pin, bolt flanges (mechanically compatible replacement for discontinued E-CON10) Pin-Numbers are printed on the sides.</p>	<p>E-CONS10-00</p>
 <p>E-CON34 E-CONS34 (pin marked connector for max. 1,5mm² cross sections)</p>	<p>For CC301T (periphery) only: Connector 2x17pin, lift & lock arms or Connector 2x17pin, bolt flanges</p>	<p>E-CON34-00 or E-CONS34-00</p>
<p>External memory</p> <p>Hint: S7-program runs without these cards, these parts are used for archiving / recipes / updating only</p> 	<p>Micro SD-card 2GB (external memory) Micro SD-card 4GB (external memory) Micro SD-card 8GB (external memory)</p>	<p>E-MSD2-00 E-MSD4-00 E-MSD8-00</p>
<p>Customized labeling</p> <p>Hint: no initial costs for creating customized labels</p>	<p>Inserting stripes with customer logo</p>	<p>none</p>
<p>Software</p> <p>Hint: ²⁾ Company license, no run-time costs per single PC ³⁾ Maintenance license Software available for free download at INSEVIS web sites</p>	<p>VisuStage, ConfigStage, RemoteStage, ServiceStage VisuStage full version company license VisuStage 1 year maintenance license VisuStage 3 year maintenance license</p>	<p>- SW-VS ²⁾ SW-VSW ³⁾ SW-VSW3 ³⁾</p>
<p>Spare parts</p> <p>Hint: A grounding terminal is part of every delivery</p>	<p>Additional set of grounding terminal for all devices</p>	<p>E-MNT00</p>
<p>Part of every delivery</p>	<p>grounding terminal technical data sheet</p>	<p>none</p>

Attached parts, customized designs and valid list prices on request from your local INSEVIS-distributor.





S7-Panel-HMI



INSEVIS S7-Panel- and EDGE-HMI –for the showcase of your product

Grade up your solution with a high class visualization to provide the essential market advantage. Comparing 2 equal solutions with the same costs buyers choose always the better looking one. With INSEVIS Panel-HMIs you will be the better one and have an economic calculation as well. Use all languages your customer needs, show fast changing screens and do not spend more than a few seconds for booting time. Every single device can be customized from 1st piece with foils, labels and firmware. IP65 leak-tightness, a wide temperature range mostly from -20°C up to +60°C and metal front and cover offer a sustainable quality value to your customer.

Encrypted communication to cloud systems via OPC UA server or MQTT is possible with the EDGE versions. A convenient web configurator fulfills the RAMI4.0 architecture and offers additional functions via NodeRED. Unique to INSEVIS: the conversion of the conservatively created visualization into JavaScript/HTML5 at the touch of a button. This means that anyone can create a web visualization.

Product groups

3,5" and 5,7" with CPU-V or-P



High value for beginners already including high-class functions

- HMI350V/P
- HMI570V/P

4,3" and 7" with CPU-T and EDGE functionality



Compact and very fast: the "small ones" with VNC- server inside

- HMI430T
- HMI430T-EDGE
- HMI710T
- HMI710T-EDGE

10,1" and 15,6" with CPU-T and EDGE functionality



Allow new project chances: the „large ones“ with CPU-T

- HMI1010T
- HMI1010T-EDGE
- HMI1560T
- HMI1560T-EDGE

Fields of application

- Display in external systems or additional to existing Panel-PLCs,
- Remote event logging and visualization in the S7-controllers network,
- Replacement of manually operated switches and 7-segment displays,
- Event display in very small switching cabinets,
- Replacement of failed or older P/TP/MP-panels, what are no more available,
- Improvement of existing visualizations

Communication to PLC

INSEVIS-S7-Panel-HMIs will be connected to the PLC by its onboard Ethernet interface (RFC 1006, S7-communication). After assigning the partner-IP-address and TSAP each in panel and PLC the configuration is done already.



External memory card

Each device has an own slot for an optional Micro-SD-card in the standard FAT32-format. This card is only needed for archiving message data, trend data as well as of data of the recipe management and for backup/restore. While updating the HMI- firmware by this card, the visualization data will kept untouched - as they were before.

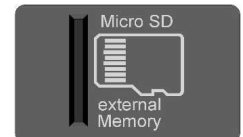

Most important properties at a glance

<p>Short system boot time – long lifetime</p> <p>No Windows-firmware means to boot up in only a few seconds and primarily: no run time licenses. And also no run-time limitations for any power tags. Therewith today's devices still may be able to update in more than 20 years...</p>	<p>Individualization with own logo</p> <p>Keep your own as bitmap fix included in your OEM- firmware, or as inserting stripe with order-no at the rear side? Everything is possible. Make you customer ordering all the time from you. No problem with INSEVIS devices....</p>
<p>Use of a standard Micro-SD card</p> <p>Archive and read out message-, trend-, recipe- and other data, create backup data directly on the device, update visualization- and firmware data An industrial Micro-SD card is just enough for that.</p>	<p>Backup & Restore – without PC</p> <p>Easy to backup all visualization and archive data – password protected as binary to use it in an identical device. This will go on working, where the old device was backed up – no need to have a computer therefore.</p>
<p>Use unlimited languages</p> <p>Support all existing languages by an innovative approach. No limitation, just use all installed languages on your PC. Don't care about translation – simple import and export functions make it easy. And -of course- no run time limitation at INSEVIS.</p>	<p>Remote access and VNC</p> <p>Use your PC-screen as 2nd panel to display and control your application remote. Import and save archive and recipe data as txt- or csv- files. Or use the VNC- server of the CPU-T-panels to control an 1:1 screen copy of the panel in mobile devices.</p>
<p>Trend display and archiving</p> <p>4 time based trends with 16 channels each can be started, stopped and continued manually or by variables. Display and archive it as you want it to do. Or display x;y-value couples from DBs in function graphs</p>	<p>Flexible multistructured recipes</p> <p>Create up to 64 recipes with up to 256 different variables (elements), what result up to 256 data records per recipe. Export and import recipes, records and elements via the Micro-SD-card.</p>
<p>Extensive error messaging system</p> <p>Display, indicate and archive up to 1024 alarms and 128 events in all your project languages, as blinking text line or symbol, as single- or multi line message viewer and -archive. Export this data automatically as csv-file to any network drive.</p>	<p>User management system</p> <p>Manage up to 9 user levers by run-time editable PINs. Define user based target screens and change screens depending on user level. Allow or deny access to „hot keys“ as you want to.</p>



S7-Panel-HMI

S7-Panel-HMIs with small displays – entrance in a new league of visualization

If as subsidiary panel, as low budget solution or as replacement of older TP/ MP: these Generation I panels will pimp your visualization with upper class functionality. Display and archive the error-messaging system, trend channels, multi structured recipes and much more with access rights from the user management system.

Go online remote wherever you want by RemoteStage. Metal front frames with protection class IP65 provides a high quality impression on the first view. Labeled with customers logo they make INSEVIS- customers inexchangeable.

The EDGE HMIs are based on the same CPU-T hardware, but a closed INSEVIS Linux derivative enables the protocols required for connection to the cloud, such as OPC UA and MQTT, which communicate securely with the IT world via VPN and encryption. Data pre-processing and visualisations can be carried out in the integrated NodeRED. An optional web server is available to host a web visualisation that is automatically created from the existing VisuStage visualisation at the touch of a button.



3,5"-devices

3,5"-display (320x240 Pixel, 4:3-format, 65.000 colors) with resistive touch
 Dimension front: 132x96mm, class of tightness: IP65, weight: ca. 450g
 Range of operation temperature: -20°C...+60°C
 Voltage supply: 24 (11...30)V DC
 Current consumption: 60mA (typ.)
 Power dissipation: 1,5W (typ.)
 Depth into switching cabinet: 49mm

A small but immense brilliant image with 65k colors and extreme compact dimensions favor this devices to be used as low budget solution or subsidiary panel in the S7-network. Low power consumption and large temperature range from -20°...+60°C expands the fields of application nearly endless. The metal front frames with protection class IP65 underlines the high quality impression just on the first view.



4,3"-devices

4,3"-display (480x272 Pixel, 16:9-format, 65.000 colors) with resistive touch
 Dimension front: 140x100mm, class of tightness: IP65, weight: ca. 450g
 Range of operation temperature: -20°C...+60°C
 Voltage supply: 24 (11...30)V DC, Current consumption: 150mA (typ.)
 Power dissipation: 3,6W (typ.), Depth into switching cabinet: 25mm
IIoT functions for EDGE devices:
 OPC UA server, MQTT (pub/sub), VPN, NodeRED,
Optional: web server for web visualization

This small but high resolutive panel in 16:9-format is characterized by its fine pixels, his fast CPU and large memory resources. Suitable for low budget solutions or subsidiary panel in the S7-network. Low power consumption and large temperature range from -20°...+60°C expands the fields of application nearly endless. The metal front frames with protection class IP65 underlines the high quality impression just on the first view.



5,7"-devices

5,7"-display (320x240 Pixel, 4:3-format, 65.000 colors) with resistive touch
 Dimension front: 182x140mm, class of tightness: IP65, weight: ca. 600g
 Range of operation temperature: -20°C...+60°C
 Voltage supply: 24 (11...30)V DC
 Current consumption: 100mA (typ.)
 Power dissipation: 2,4W (typ.)
 Depth into switching cabinet: 49mm

For those who miss the TP/MP177 panels from Siemens, this unit will be the solution: 320x240 pixel in 4:3 format at 5,7" diagonal with 65k colors better up old solutions by far and keep it alive for lots of years. There are so much more functions, solved in an easier way. A visualization is created, modified or converted into another panel in a very short time. The same resolution like the 3,5"-panels (QVGA) allows to offer different price levels with the exactly same visualization.

Article no.	CPU	Ethernet	Display-diagonal	Number of pixels (WxH)	Visualization-memory	Remote display in addition to Partner PLC via RemoteStage
HMI 350V-03	-V	√	3,5" / 89mm	320x240	4MB	
HMI 350P-03	-P	√	3,5" / 89mm	320x240	24MB	
HMI 430T-03	-T	2 √	4,3" / 111mm	480x272	48MB	4x VNC-Server
HMI 430TE-03	-T	2 √	4,3" / 111mm	480x272	¹⁾	NodeRED-Dashboard
HMI 430TEW-03	-T	2 √	4,3" / 111mm	480x272	¹⁾	NodeRED-Dashboard, Webvisu
HMI 570V-03	-V	√	5,7" / 145mm	320x240	4MB	
HMI 570P-03	-P	√	5,7" / 145mm	320x240	24MB	

¹⁾ Shared media usage of HMI-Visu, WebVisu, trend, alarm/event archive, OPC UA history, NodeRED 300 MB



S7-Panel-HMIs with middle and large displays – masters of the low-budget projects

With these panels you rise up into another league. What was impossible by rationality reasons can be realized now with these units. Never before you could visualize your know-how that easy and that economic in a German quality level. Use this chance to create a huge showcase to impress your customers.

The power of the new CPU-T allow functions, what where reserved for IPCs before. Use 1024 alarms, 128 events, 64 recipes with 256 elements and 256 records, 64 trend channels, 8 users unlimited and for free. Up to 5 panels can be combined with an INSEVIS S7-PLC by Ethernet.



7" devices

Dimension front: 222x147mm, class of tightness: IP65, weight: ca. 600g
 Range of operation temperature: -20°C...+60°C
 7"-display (800x480 Pixel, 16:9-format, 65.000 colors) with resistive touch
 Voltage supply: 24 (11...30)V DC, Current consumption: 200mA (typ.),
 Power dissipation: 4,8W (typ.), Depth into switching cabinet: 45mm

IIoT functions for EDGE devices:
 OPC UA server, MQTT (pub/sub), VPN, NodeRED,
Optional: web server for web visualization

These panels with its 7"-diagonals fit perfect for medium sized applications because of its huge functionality. The modern 16:9-format allows to visualize more objects in one screen – good for trend graphs as well. The share the same cut out dimensions to allow scalable series with similar front cut outs. So you can create your own modular system without any additional costs.



10"-devices

Dimension front: 286x188mm (like PC1010), class of tightness: IP65, weight: ca. 1000g
 Range of operation temperature: -20°C...+60°C
 10,1"-display (1024x600 Pixel, 16:9-format, 65.000 colors), resistive Touch
 Voltage supply: 24 (11...30)V DC, Current consumption: 350mA (typ.),
 Power dissipation: 8,4W (typ.), Depth into switching cabinet: 47mm

IIoT functions for EDGE devices:
 OPC UA server, MQTT (pub/sub), VPN, NodeRED,
Optional: web server for web visualization

These panels have more pixels on nearly the same diagonal of 10". The image is more fine or brilliant than before and your objects can be displayed with a higher resolution. And there is enough space and functionality to impress your customer by this brilliant and fast switching panel. The also share the same cut out dimensions to allow scalable series with similar front cut outs.



15,6"-devices

Dimension front: 410x250, class of tightness: IP65, weight: ca. 1400g
 Range of operation temperature: 0°C...+50°C
 15,6"-Display (1366x768 Pixel, 16:9-format, 65.000 colors) with resistive touch
 Voltage supply: 24 (11...30)V DC, Current consumption: 500mA (typ.)
 Power dissipation: 12W (typ.), Depth into switching cabinet: 54mm

IIoT functions for EDGE devices:
 OPC UA server, MQTT (pub/sub), VPN, NodeRED,
Optional: web server for web visualization

This size is actual the largest INSEVIS-Panel-HMI and the CPU-T has enough power to switch display menus very fast to impress your customer. Why not grading up your application by this huge panel? You will have no problem in communication with Siemens-S7-CPU's by Ethernet (active S7-communication). And you still will have no problem in your project cost estimation. Create your brand in a customized firmware to display your own automation competence.

Article no.	CPU	Ethernet	Display-diagonal	Number of pixels (WxH)	Visualization-memory	Remote display in addition to Partner PLC via RemoteStage
HMI 710T-03	-T	2 ✓	7" / 180mm	800x480	48MB	4x VNC-Server
HMI 710TE-03	-T	2 ✓	7" / 180mm	800x480	1)	NodeRED-Dashboard
HMI 710TEW-03	-T	2 ✓	7" / 180mm	800x480	1)	NodeRED-Dashboard, Webvisu
HMI 1010T-03	-T	2 ✓	10,1" / 257mm	1024x600	48MB	4x VNC-Server
HMI 1010TE-03	-T	2 ✓	10,1" / 257mm	1024x600	1)	NodeRED-Dashboard
HMI 1010TEW-03	-T	2 ✓	10,1" / 257mm	1024x600	1)	NodeRED-Dashboard, Webvisu
HMI 1560T-03	-T	2 ✓	15,6" / 397mm	1366x768	48MB	4x VNC-Server
HMI 1560TE-03	-T	2 ✓	15,6" / 397mm	1366x768	1)	NodeRED-Dashboard
HMI 1560TEW-03	-T	2 ✓	15,6" / 397mm	1366x768	1)	NodeRED-Dashboard, Webvisu

1) Shared media usage of HMI-Visu, WebVisu, trend, alarm/event archive, OPC UA history, NodeRED 300 MB



Valid list prices on request from your local INSEVIS-distributor.



Accessories for S7-Panel-HMIs

There are available pin marked removable connectors either with lift arms or with bolt flanges to connect INSEVIS devices. This allows a explicit positioning of each pin to the signals and makes the wiring easier. The wire-contact is done by maintenance free cage-clamps for max. 1,5mm² cross sections without wire end sleeves.

A mounting set with grounding terminal is part of every delivery.

Figure of accessories	Accessories	Article no.
<p>Connectors</p>  <p>E-CONS16 (pin marked connectors for max. 1,5mm² cross sections)</p>	<p>For devices with CPU V/P: Connector 2x8pin, bolt flanges (mechanically compatible replacement for discontinued E-CON16)</p> <p>Pin-numbers are printed on the sides.</p>	E-CONS16-00
 <p>E-CONS10 (pin marked connectors for max. 1,5mm² cross sections)</p>	<p>For devices with CPU T: Connector 2x5pin, bolt flanges (mechanically compatible replacement for discontinued E-CON10)</p> <p>Pin-Numbers are printed on the sides.</p>	E-CONS10-00
<p>External memory Hint: S7-program runs without these cards, these parts are used for archiving / recipes / updating only</p> 	<p>Micro SD-card 2GB (external memory) Micro SD-card 4GB (external memory) Micro SD-card 8GB (external memory)</p>	E-MSD2-00 E-MSD4-00 E-MSD8-00
<p>Customized labeling Hint: ¹⁾ Single fix costs only, no run-time costs per single HMI</p>	<p>OEM- firmware with integrated customer logo Inserting stripes H with customer logo (rear)</p>	SW-BS-OEM ¹⁾ E-LABH-00
<p>Software Hint: ²⁾ Company license, no run-time costs per single PC ³⁾ Maintenance license due yearly, if new versions are required, otherwise only old versions do run Software available for free download at INSEVIS web sites</p>	<p>VisuStage, ConfigStage, RemoteStage, ServiceStage VisuStage full version company license VisuStage 1 year maintenance license VisuStage 3 year maintenance license</p>	- SW-VS ²⁾ SW-VSW ³⁾ SW-VSW3 ³⁾
<p>Spare parts Hint: A mounting set with grounding terminal is part of every delivery</p>	<p>Additional mounting set with grounding terminal for 3,5" and 4,3"-devices Additional mounting set with grounding terminal for 5,7" and 7"-devices Additional mounting set with grounding terminal for 10,1"-devices Additional mounting set with grounding terminal for 15,6"-devices</p>	E-MNT35-00 E-MNT57-00 E-MNT101-00 E-MNT156-00
<p>Part of every delivery</p>	<p>mounting set with grounding terminal technical data sheet</p>	none

Stainless steel front plates, attached parts and customized designs on request.





Periphery

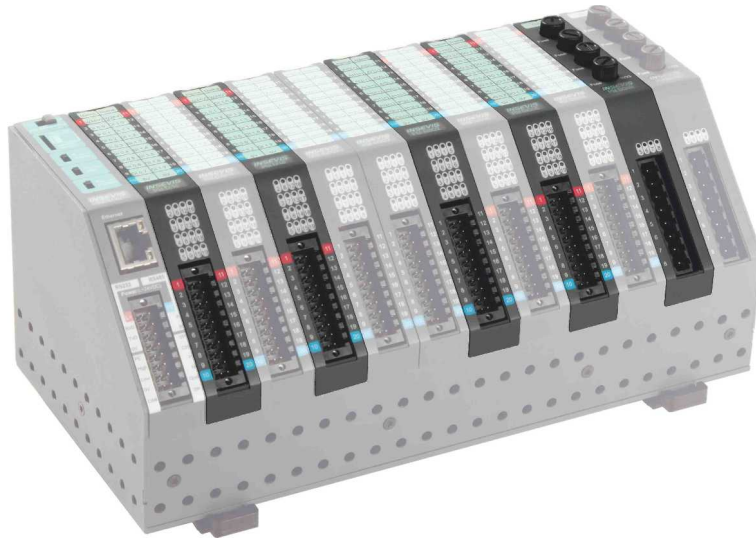

INSEVIS Periphery – large steps with fine modules

Simplify your periphery by selecting the functionality as digital input or output bitwise by a mouse click. Assign the wiring of analog inputs as 2-, 3- or 4- wire configuration or increase the resolution from 12 to 16 bit by entering another integration time. This makes you faster and more flexible, provides more reserve I/Os and leads to a better customer satisfaction.

All INSEVIS- periphery and function modules can be used either onboard (in the periphery slots of Compact-PLCs or Panel-PLCs) or decentral (in the periphery slots of decentral periphery stations / -blocks). In every case there are 3, 7 or 11 free periphery slots to place any of these modules. The range of modules is under permanently extension by standard and customers designs.

The good viewable status LEDs, self-printable insertion stripes on metal housings are exemplary in that class. These provides a very high class impression of your product to your customer. But the best of all: the configuration software is so easy, that every configuration becomes a child's play. Use INSEVIS external periphery like onboard periphery and do not mind about difficult addressing.

Product groups

Head stations



The easiest way to your decentral periphery

- DP301C
- DP303C
- DP307C
- DP311C

Digital modules



Flexible down to each bit - the compact digital modules

- PM-DI16
- PM-DIO16
- PM-DO4R
- PM-MIO84

Analog modules



Variable, precise and stable – but still enormous economic

- PM-AI8
- PM-AI4O4
- PM-AI8O2
- PM-RTD8O2

Function modules / Energy modules



Simple use of counters or energy sampling modules

- PM-DIO8Z
- PM-E-MESS-UI

Fields of application

- Compact and economic decentral periphery for INSEVIS- or other external PLCs
- Modular adaption to every application by fine grades of I/Os
- Very easy configuration of decentral periphery
- Direct access to encoders, counters
- Direct accessing of energy data in the S7-process image
- Need extremely low price? Ask for your own customized designed as CAN-slave



Communication to PLC

While onboard periphery has its access to INSEVIS S7-CPU by the integrated rear bus, the head stations of the decentral periphery communicate with the CPUS by a protocol, compatible to CANopen®. Because CAN is not so common in the S7-world, INSEVIS maps its decentral periphery only by inserting the CAN-node ID. All others is done automatically and no INSEVIS customer needs to know anything about CAN.



Periphery products, generally



Data valid for all periphery and function modules:

Property	Technical data
Operating temperature range	-20°C ... +60°C (without condensation)
Storing temperature range	-30°C ... +80°C
Dimension (W x H x D)	20 x 108 x 70 mm
Weight	ca. 150 g
Wire length unshielded (max.)	30 m
shielded (max.)	100 m
Connection technology	Cage clamp technology for cross section up to max. 1,5mm ²

Hint:

More Product information to all modules are available at INSEVIS web sites in the Product / Periphery - area and contain more information for wiring and block schemes

A pin marked 20-pin connector with lift arms or bolt flanges is available for every module (for PM-DO4-R only an 8pin connector)

Most important properties at a glance

High packing factor

By a module width of < 20mm lots of I/Os fit in a compact PLC or decentral head station.
A slim mounting depth of < 95mm and an angled connection layer towards the cable channel pre-assembled cable harness

Easy configurable head station

Assign decentral head stations by 2 node-IDs only.
Once directly at the head stations turn switches and once in the cost free configuration software.
That's all.

High resolution

All analog INSEVIS-I/Os resolution is minimum 12Bit
If you allow a little more integration time to the inputs of AI4O4, you can increase this resolution up to 16Bit.
Of course without more costs. As always at INSEVIS.

Intelligent configuration





Selecting the functionality bitwise as digital input or output.
Assign the wiring of analog inputs as 2-, 3- or 4- wire configuration.
Choose between current or voltage an analog I/Os.
Do it all by a mouse click in the cost free configuration software.



Periphery

Decentral head stations

These head stations can support all INSEVIS- periphery and function modules. Either 3 or 7 or 11 free periphery slots are there for carry INSEVIS modules. The rear foils on the metal cover shows the color of the marked connector pushers to guarantee a perfect identification of signals and connector pins. This provides a very high quality impression. Every slot can be shown in customized labels.

	<p>Periphery block with fixed onboard periphery</p> <p>Dimensions: 20 x 116 x 92mm, Weight: ca. 250g Range of operation temperature: -20°C...+60°C</p> <ul style="list-style-type: none"> - 12 digital inputs (24V), thereof 2 counter 1kHz and 2 counter (ABZ) 100kHz - 12 digital in-/outputs (24V/0,5A), thereof 2 PWM and 2 push pull outputs - 3 analog in- or outputs, each channel as I or O in voltage or current - 3 analog inputs as voltage or current or as 2 TC, 3 RTD or 1strain gauge <p>Voltage supply: 24 (11...30)V DC, Current consumption: 20...25 mA (typ.) ... 100mA (max.), Power dissipation: 0,6...1,2W (typ.) ... 2,4W (max.) dl/dO latency time < 1ms, max. frequency (dl/dO) 50 Hz</p>
 <p>figure shows onboard periphery (optionally)</p>	<p>Head stations with 3 free slots for modular onboard periphery</p> <p>Dimensions: 82 x 116,5 x 92mm, Weight: ca. 400g Range of operation temperature: -20°C...+60°C with 3 free slots for INSEVIS periphery onboard:</p> <ul style="list-style-type: none"> - max. 48 digital inputs (24V) or 18 counter (5V/24V/RS422) - max. 48 digital outputs (24V/0,5A) or 12 relays (230V/3A) - max. 24 analog inputs (U/I/PT) or 12 analog outputs (U/I) - max. 12 current- and 9 voltage measurements by E-Mess-UI <p>Voltage supply: 24 (11...30)V DC Current consumption: 20 mA (typ.) ... 275 mA (max. with PMs) Power dissipation: 0,5 W (typ.) ... 4,5 W (max. with PMs) Sampling cycle time: 0,1 ... 0,250 ms (typ.)</p>
 <p>figure shows onboard periphery (optionally)</p>	<p>Head stations with 7 free slots for modular onboard periphery</p> <p>Dimensions: 162 x 116,5 x 98mm, Weight: ca. 600g Range of operation temperature: -20°C...+60°C with 7 free slots for INSEVIS periphery onboard:</p> <ul style="list-style-type: none"> - max. 112 digital inputs (24V) or 42 counter (5V/24V/RS422) - max. 112 digital outputs (24V/0,5A) or 28 relays (230V/3A) - max. 56 analog inputs (U/I/PT) or 28 analog outputs (U/I) - max. 28 current- and 21 voltage measurements by E-Mess-UI <p>Voltage supply: 24 (11...30)V DC Current consumption: 20 mA (typ.) ... 775 mA (max. with PMs) Power dissipation: 0,5 W (typ.) ... 16,5 W (max. with PMs) Sampling cycle time: 0,1 ... 0,250 ms (typ.)</p>
 <p>figure shows onboard periphery (optionally)</p>	<p>Head stations with 11 free slots for modular onboard periphery</p> <p>Dimensions: 240 x 116,5 x 98mm, Weight: ca. 800g Range of operation temperature: -20°C...+60°C with 11 free slots for INSEVIS periphery onboard:</p> <ul style="list-style-type: none"> - max. 176 digital inputs (24V) or 66 counter (5V/24V/RS422) - max. 176 digital outputs (24V/0,5A) or 44 relays (230V/3A) - max. 88 analog inputs (U/I/PT) or 44 analog outputs (U/I) - max. 44 current- and 33 voltage measurements by E-Mess-UI <p>Voltage supply: 24 (11...30)V DC Current consumption: 20 mA (typ.) ... 1275 mA (max. with PMs) Power dissipation: 0,5 W (typ.) ... 28,5 W (max. with PMs) Sampling cycle time: 0,1 ... 0,250 ms (typ.)</p>

Article name	Article no.	Article name	Article no.
Fixed periphery block DP301C	DP301C-02	Connector 2x3pin, bolt flanges (DP301C)	E-CONS06-00
Decentral head station DP303C	DP303C-02	Connector 2x17pin, lift & lock arms (DP301C)	E-CON34-00
Decentral head station DP307C	DP307C-02	Connector 2x17pin, bolt flanges (DP301C)	E-CONS34-00
Decentral head station DP311C	DP311C-02	Connector 2x5pin, bolt flanges (other DP3xxC)	E-CONS10-00

Valid list prices on request from your local INSEVIS-distributor.



Periphery module DI16 (16 digital inputs 24V)

The periphery module PM-DI16 is a compact periphery module for 16 digital inputs 24V

PM-DI16

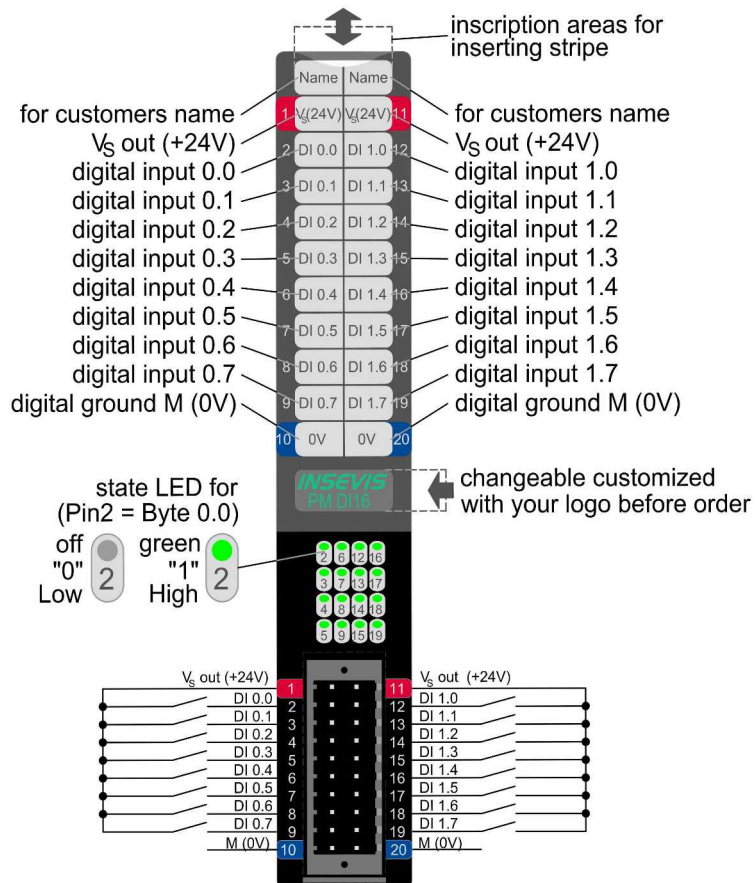

Property	Technical data
Sensor supply	short circuit proof output, current limited to 30 mA (typ.)
Load voltage L+	24V DC (11V ... 30V DC, is connected by device supply)
Digital inputs Diagnostic LEDs	16 16, green
Input voltage for signal 0 for signal 1	0V ... +5 V +7,5V ... +30 V
Input current for signal 1	1 mA
Broken wire detection Potential separation to PLC Access of 2-wire-BERO	no no no
Input delay Output delay Sampling cycle time	90 μ s (typ.) 1,4 ms (typ.) as onboard module on the PLC = cycle synchronous

Hint:

More product information to this module is available at INSEVIS web sites in the Product / Periphery - area and contain more information for wiring and block schemes.

Order data	Article no.
Periphery module DI16	PM-DI16-02
Connector 2x10pin with bolt flanges	E-CONS20D-00

Valid list prices on request from your local INSEVIS-distributor.



Periphery

Periphery module DIO16 (16 digital in- or outputs 24V / 0,5A)

The periphery module PM-DIO16 is a compact I/O-board for 16 digital transistor outputs 24V / 0,5A, each with back-readable inputs. When the output is deselected, every bit can be used as input as well.

PM-DIO16

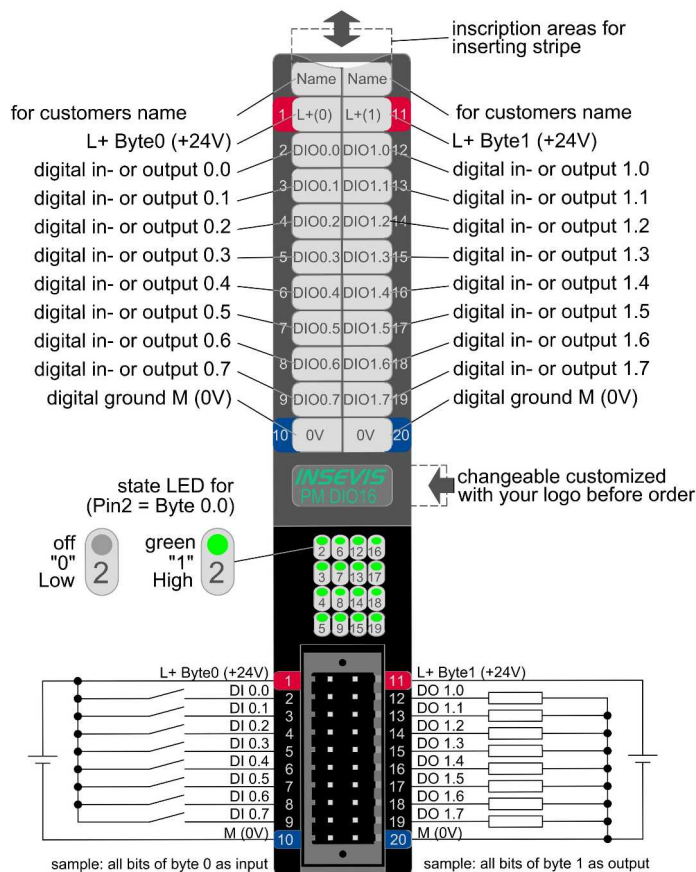

Property	Technical data
Load voltage L+	10 V ... 30 V DC
Current consumption Power dissipation	50 mA (max.) without load internal limited
Digital in-/ outputs	16 in- or outputs (adjustable by software) 16, green
Diagnostic LEDs	16, green

Outputs	Technical data
Output current for signal 0 for signal 1	0,5 mA (max.) 0,5 A (max. to 60°C)
Cumulated curred per output-byte	3 A (max. to 60°C)
Signal level of outputs for signal 0 for signal 1	1,0 V at 500 Ω (max.) L+ - 1,0 V / 0,5 A load (min.)
Input delay Output delay	50 μs (typ.) 30 μs (typ., without load)
Max. switching frequency with ohmic load	100 Hz

Inputs	Technical data
Input current for signal 1	1 mA (typ.)
Input voltage for signal 0 for signal 1	0V ... +5 V +7,5V ... +30 V
Input delay Output delay Sampling cycle time	1,5 ms (typ.) 4,6 ms (typ.) synchronous to cycle
Broken wire detection Error diagnostic Potential separation to PLC	no no no

Hints:

Every Byte has an own voltage supply, what offers a switch-off of the whole byte.

More product information to this module is available at INSEVIS web sites in the Product / Periphery - area and contain more information for wiring and block schemes

Order data	Article no.
Periphery module DIO16	PM-DIO16-02
Connector 2x10pin with bolt flanges	E-CONS20D-00

Valid list prices on request from your local INSEVIS-distributor.



Periphery module DO4R (4 relay outputs 230V) / 3A

This periphery module PM-DO4-R is a compact periphery module for 4 relay outputs 230V AC (4 potential separated contacts) with 4 glass bulb fuses 5x20mm (1 for each relay)

PM-DO4R

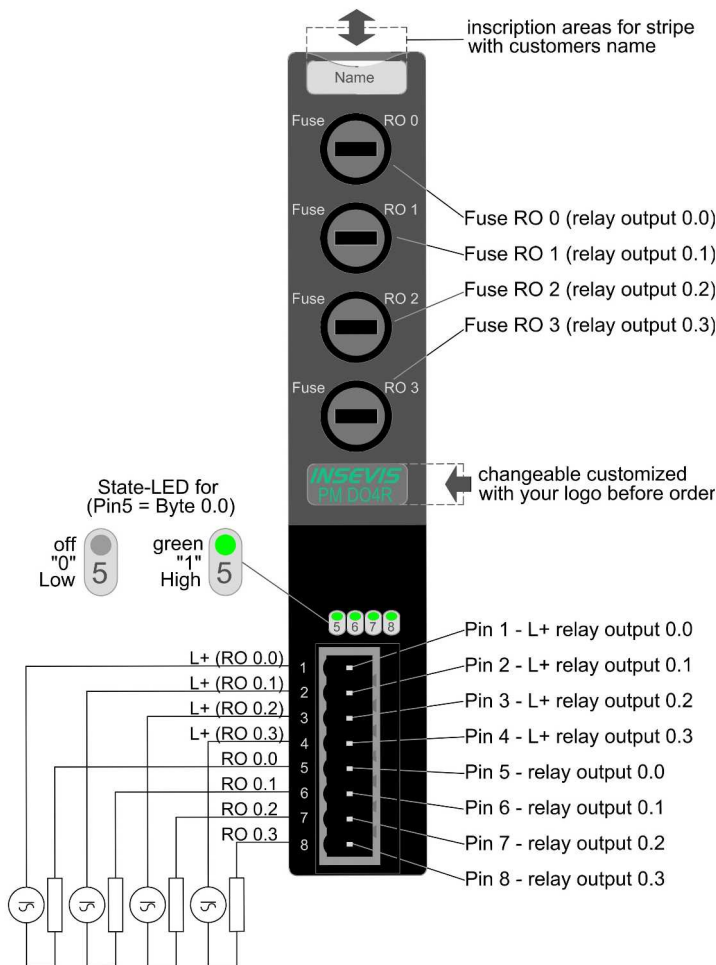

Property	Technical data
Load voltage L+	24 V (17 V ... 30 V, connected by device supply)
Load voltage L+ on the relay	30 V DC (max.), 250 V AC (max.)
Current consumption Power dissipation	45 mA from L+ (max.) 0,8 W at 24V (max.)
Digital outputs Diagnostic LEDs	4 4, green
Topography	4 potential separated contacts with fuse and RC (between Pins 1-5, 2-6, 3-7, 4-8)
Input delay	5 ms ... 10 ms (typ.)
Output delay	2 ms ... 5 ms (typ.)
Switching capacity of contacts at inductive load at ohmic load	3A (max.) 3A (max.)
Max. switching frequency mechanical with load	50 Hz 5 Hz
Typ. number of switching operations mechanical with 3A	20Mio 100.000
Broken wire detection Error diagnostic Potential separation to PLC	no no yes
Short circuit proof	yes - melting fuse in glass bulbs 5x20mm (3A fast)

Hints:

Because of the fuses (must be accessible directly from the outside and need a prepared drill in the metal cover) a placement in the las 3 periphery slots is possible.

More product information to this module is available at INSEVIS-web sites in the Product / Periphery - area and contain more information for wiring and block schemes

Order data	Article no.
Periphery module DO4-R	PM-DO4R-02
Connector 1x8 pin	E-CON08-00

Valid list prices on request from your local INSEVIS-distributor.



Periphery

Periphery module MIO84 (8 digital- and 4 analog in- or outputs)

The periphery module PM-MIO84 is a compact module with mixed digital and analog inputs or outputs and counter function. It is designed for all those, who have to control only a few digital and analog signals and maybe something to count. The I/O-configuration is done by ConfigStage- software, where the integration time is assigned (expands resolution from 12...16Bit).

PM-MIO84

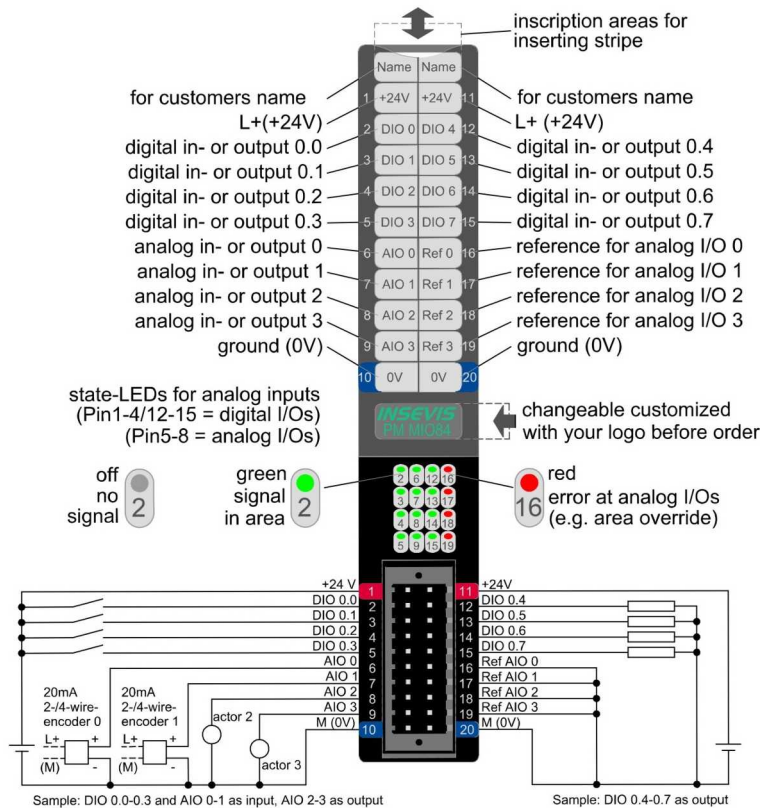

Digital inputs or outputs

Property	Technical data
Load voltage L+	24V DC (17 V ... 30 V DC) connected by device suppl.
Digital in- / outputs	8 in- or outputs
Diagnostic LEDs	8, green
Outputs: switch on delay switch off delay	50 μ s (typ.) 30 μ s (typ., without load)
Inputs: switch on / off delay	25 μ s
Output current for signal 0 for signal 1	0,5 mA (max.) 0,5 A (max. to 60°C)
Switching freq of outputs	max100 Hz with ohmic load
Cumulated current	2 A (max. to 60°C)
Counter	2 -each as forward counter, forward/backward counter or incremental encoder
Frequency limit	25 kHz
Broken wire detection Error diagnostic Potential sep. to PLC	no no

Analog inputs or outputs

Property	Technical data
Load voltage L+	24V DC (17 V ... 30 V DC) connected by device suppl.
Analog inputs	4 (alternatively to outputs, what is SW-configurable)
Input areas	\pm 20 mA, 4...20 mA, 0...10 V
Diagnostic LEDs (no displaying broken wires and open inputs)	4, green: signal in valid area 4, red: override or saturation
Specificity	< 1%
Analog outputs	4 (alternatively to inputs, what is SW-configurable)
Output areas	0...20mA, 4...20mA, \pm 10V
Diagnostic LEDs	4, green in valid area 4, red override or load error
Setting time / response time	τ = 1,5 ms (typ)
Load resistance against A-GND	mA: 500 Ω (max.) V: 1 k Ω (min.)
Resolution depending on integration time	Analog inputs: 12...16 Bit Analog outputs: 12 Bit
Precision (typ.)	< 1%

Hints:

Connect Ref AIO 0..3 with ground (0V) always.

This module has an internal supply for the 2-wire encoders. So it is not necessary to care for external supply!

More product information to this module is available at INSEVIS web sites in the Product / Periphery - area and contain more information for wiring and block schemes and 3-/4 wire applications.

Order data	Article no.
Periphery module MIO84	PM-MIO84-02
Connector 2x10pin with bolt flanges	E-CONS20D-00

Valid list prices on request from your local INSEVIS-distributor.



Periphery module AI8 (8 analog inputs)

The periphery module PM-AI8 is a compact pure analog module with 8 analog inputs, configurable by software. It could fit to all who need more analog inputs than outputs. The I/O-configuration is done by ConfigStage-software, where the integration time is assigned (expands resolution from 12...16Bit).

PM-AI8

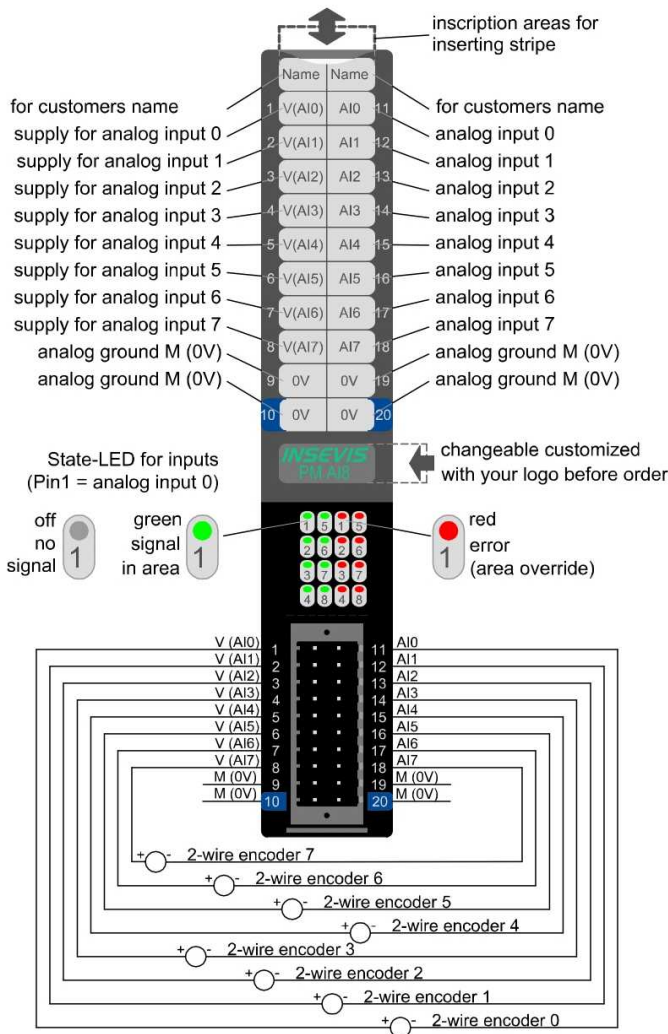

Analog inputs

Property	Technical data
Load voltage L+	24V DC (17 V ... 30 V DC) connected by device suppl.
Number of inputs	8 (configurable by software)
Input areas	0 ... 20mA 4 ... 20mA, ± 2,5V ± 5V ± 10 V 0 ... 10V
Diagnostic LEDs (no displaying broken wires and open inputs)	8, green: signal in valid area 8, red: override or saturation
Value number format	0000 ... 6C00 (hexadecimal) for range mA and 1...5/0...10V all other 9400 ... 6C00 (hex.)
Override area	20 mA ... 22 mA (only at mAs)
Input resistance	150Ω (typ.) metering area current 100kΩ (typ.) metering area voltage
Sampling cycle time = Integration time *	adjustable 1ms ... 35767 ms default: 100 ms (=Net frequency filter 50Hz and 60Hz)
Valid voltage between inputs and A-GND (max.)	-15 ... +24 V DC
Broken wire detection	by overrun/ shortfall of metering area
Access of sensor	unsymmetric against A-GND (single ended)
Metering principle / conversion principle Resolution depending on integration time *	successive approximation 12 Bit ... 16 Bit
Specify (based on input area)	< 1%

Hints:

More product information to this module is available at INSEVIS web sites in the Product / Periphery - area and contain more information for wiring and block schemes and 3-/4 wire applications.

Order data	Article no.
Periphery module AI8	PM-AI8-02
Connector 2x10pin with bolt flanges	E-CONS20A-00

Valid list prices on request from your local INSEVIS-distributor.



Periphery

Periphery module AI4O4 (4 analog in- and 4 analog outputs)

The periphery module PM-AI4O4 is created for customers who need flexible analog I/Os. Every input and every output can assigned by ConfigStage to another value area. The resolution increases from 12 to 16 bit depending on assigned integration time.

PM-AI4O4

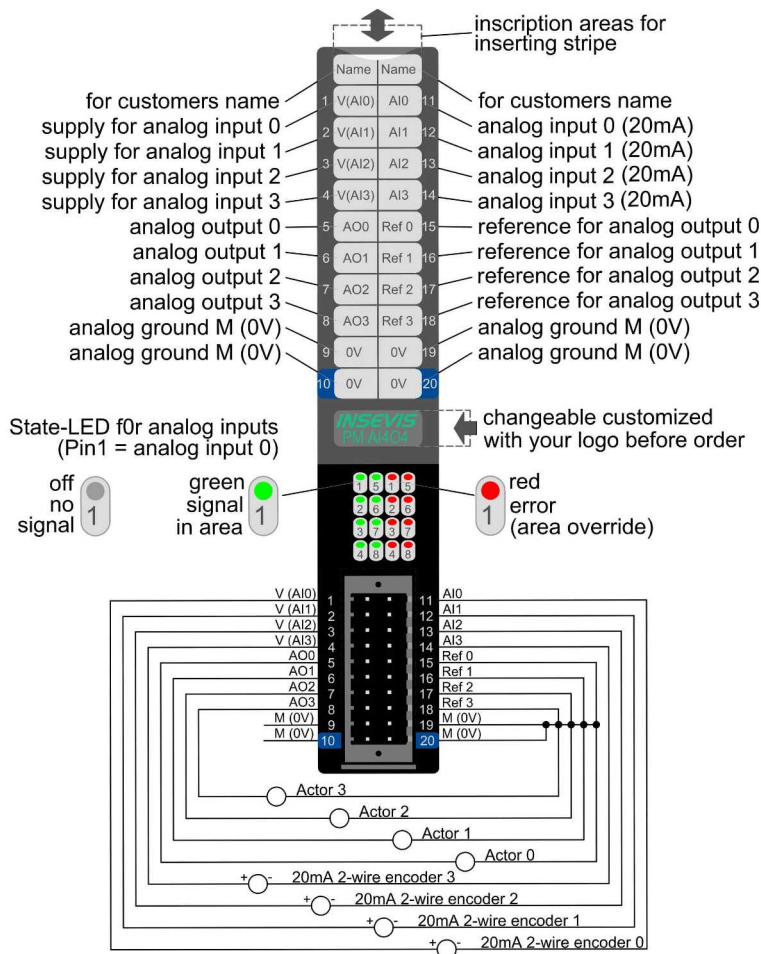

Analog inputs

Property	Technical data
Load voltage L+	24V DC (17V ... 30V DC, connected by device supply)
Current consumption	150 mA (max.)
Power dissipation	4 W (max.)
Analog inputs	4 (configurable by software)
Input area (nominal values)	0...20mA, 4...20mA ±10V ±5V ±2,5V 0..10V
Diagnostic LEDs (no displaying broken wires and open inputs)	4, green: signal in valid area 4, red: override or saturation
Valid voltage between inputs and A-GND (max.)	-15 V ... +24 V DC
Broken wire detection	by overrun / shortfall of metering area
Sampling cycle time = Integration time	adjustable 1ms ... 35767 ms default: 100 ms
Resolution depending on integration time	12...16 Bit
Precision (typ.)	< 1% (based on output area)

Analog outputs

Property	Technical data
Analog outputs	4 (configurable by software)
Output area (nominal values)	±20mA, 4...20mA, ±10V
Diagnostic LEDs green: Diagnostic LEDs red	4: green: signal in valid area 4 red: override(mA) / short circuit
Setting time / response time	$\tau = 1,5 \text{ ms (typ)}$
Load resistance against A-GND	mA: 500 Ω (max.) V: 1 k Ω (min.)
Short cut protection	ja
Override area	20 ... 23 mA, -20 ... -23 mA 10 ... 11,3V, -10 ... -11,3V
Resolution	12 Bit
Precision (typ.)	< 1% (based on output area)

Hints:

This module has an internal supply for the 2-wire encoders. So it is not necessary to care for external supply!

More product information to this module is available at INSEVIS web sites in the Product / Periphery - area and contain more information for wiring and block schemes and 3-/4 wire applications.

Order data	Article no.
Periphery module AI4O4	PM-AI4O4-02
Connector 2x10pin with bolt flanges	E-CONS20A-00

Valid list prices on request from your local INSEVIS-distributor.



Periphery module AI8O2 (8 analog in- and 2 analog outputs)

The compact periphery module PM-AI8O2 is a fix designed product without any software assignments. It is made as a low cost module for basic applications with PT100 and current inputs and current outputs.

PM-AI8O2

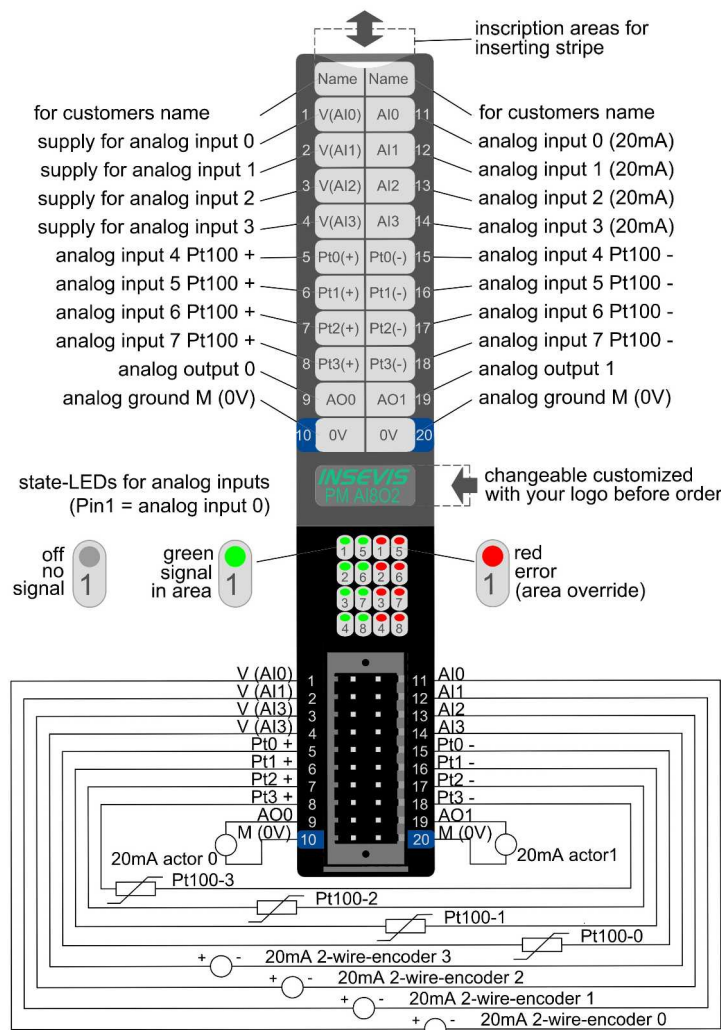

Analog inputs

Property	Technical data
Load voltage L+	24V DC (17V ... 30V DC, connected by device supply)
Current consumption Power dissipation	150 mA (max.) 2 W (max.)
Input area (nominal values)	AE 0...3: 4... 20 mA AE 4...7: PT100 metering range (80°C .. 300°C)
Override area	20 mA ... 23 mA
Diagnostic LEDs no displaying broken wires and open inputs	8 green: signal in valid area 8 rot: override (mA) or short circuit or temperature value below -50°C (PT100)
Input resistance (typ.)	150 Ω metering area 20 mA 500 Ω metering area PT100
Sampling cycle time = Integration time	adjustable 1ms ... 35767 ms default: 100 ms
Resolution	12 Bit
Precision (typ.)	< 1% (based on output area)

Analog outputs

Property	Technical data
Analog outputs	2
Output area (nominal values)	4 mA ... 20 mA
Override area	20 mA ... 23 mA
Analog outputs	2
Short cut protection	yes
Setting time	response time τ (typ) 5 ms
Resolution	12 Bit
Precision (typ.)	< 1% (based on output area)

Hints:

This module has an internal supply for the 2-wire encoders. So it is not necessary to care for external supply!

More product information to this module is available at INSEVIS web sites in the Product / Periphery - area and contain more information for wiring and block schemes and 3-/4 wire applications.

Order data	Article no.
Periphery module AI8O2	PM-AI8O2-02
Connector 2x10pin with bolt flanges	E-CONS20A-00

Valid list prices on request from your local INSEVIS-distributor.



Periphery

Periphery module RTD802 (8 analog in- and 2 analog outputs)

The periphery module PM-RTD802 is a compact module designed for applications to measure resistances like PT100/1000, NI100/1000, KTY81 etc. There can be configured 2-, 3- and 4-wire connections, what makes this product very flexible. 2 voltage outputs are too.

PM-RTD802

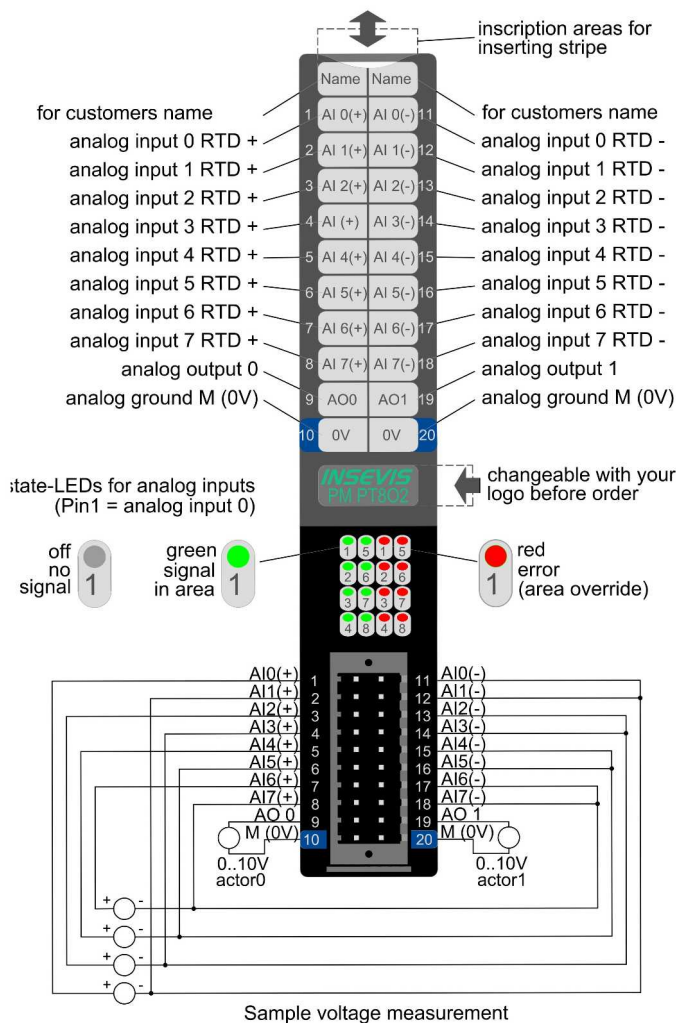

Analog inputs

Property	Technical data
Load voltage L+	24V DC (17V ... 30V DC, connected by device supply)
Current consumption	50 mA (max.)
Power dissipation	1,2 W (max.)
Analog inputs	8
Diagnostic LEDs	8 green: signal in valid area 8 red: short circuit, no displaying broken wires and open inputs
Input area (nominal values)	PT100: -50°C .. 600°C PT1000: -50°C .. 250°C Ni100: -50°C .. 250°C Ni1000: -50°C .. 150°C KTY81/1xx: -50°C .. 150°C 0 ... 300 Ω, 0... 2 kΩ
Input resistance	500 Ω (typ.) metering area PT100
Sampling cycle time = Integration time	adjustable 1ms ... 35767 ms default: 100 ms
Access of sensor	2- or 4- wire, symmetric
Broken wire detection	by overrun / shortfall of metering area
Resolution	12 Bit
Precision (typ.)	< 1% (based on input area)

Analog outputs

Property	Technical data
Analog outputs	2
Output area (nominal values)	0 ... 10V
Override area	0 ... 11V
Load resistance against A-GND	1kΩ (max.)
Short cut protection	yes
Short cut current (typ.)	32 mA
Setting time (typ)	response time τ 1,5 ms
Resolution	12 Bit
Precision (typ.)	< 1% (based on output area)

Hint:

More product information to this module is available at INSEVIS web sites in the Product / Periphery - area and contain more information for wiring and block schemes and 3-/4 wire applications.

Order data	Article no.
Periphery module RTD802	PM-RTD802-02
Connector 2x10pin with bolt flanges	E-CONS20A-00

Valid list prices on request from your local INSEVIS-distributor.



Function module DIO8-Z (2 encoder channels and 2 digital in- or outputs)

The function module DIO8-Z is a compact counter module with 6 counter inputs. Therewith e.g. 2 encoder (A,B,Z) with 5V, 24V or 2 absolute encoder (RS422) can be connected. This module provides 2 digital inputs or outputs (2A) too.

PM-DIO8-Z

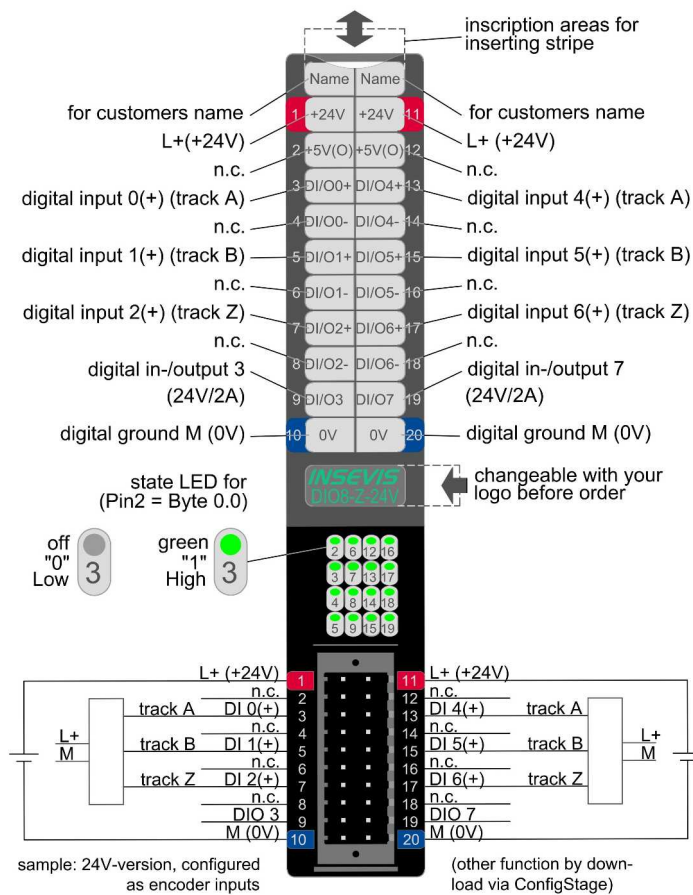

Counter inputs

Property	Technical data
Digital inputs	6 inputs
Diagnostic LEDs	6, green
Input voltage	positive switching negative switching
5V and 24V	
Inputs ref. RS422	differential (ref. to RS422)
Broken wire detection	no
Potential separation to PLC	no
Access of 2-wire-BERO	no
Input delay	2 μs (typ.)
Output delay	2 μs (typ.)
Max. counting frequency	125kHz (subject to change)

Digital inputs or outputs

Property	Technical data
Outputs	
Output signal level	1,0 V at 500Ω (max.) L+ -1,0V at 0,5A load (min.)
Output current	0,5mA (max.) 2 A (max. to 60°C) (subject to change)
Output delay	30 μs (typ., without load)
Max. switching frequency with ohmic load	100 Hz
Inputs	
Input signal level	0V ... +5V +7,5V ... +30V
Broken wire detection	no
Error diagnostic	no
Potential separation to PLC	no
Input delay	50 μs (typ.)

Hints:

More product information to this module is available at INSEVIS web sites in the Product / Periphery - area and contain more information for wiring and block schemes and other decoders.

Select your functionality by freeware "ConfigStage" and download it into the DIO8Z. The S7-CPU will be informed automatically

Order data	Article no.
Function module DIO8-Z for 24V signals	PM-DIO8Z-24V-03
Function module DIO8-Z for 5V signals	PM-DIO8Z-5V-03
Function module DIO8-Z for RS422 signals	PM-DIO8Z-422-03
Connector 2x10pin with bolt flanges	E-CONS20D-00

Valid list prices on request from your local INSEVIS-distributor.



Periphery

Function module E-Mess UI (3 voltage- and 4 current transformer inputs for L1-L3, N)

The function module E-Mess UI is a compact module with mixed voltage and current sampling inputs for energy measurement of a consumer in a 3 phase grid. This module samples current of 4 phases and voltage of 3 phases as well as the phase angle. An internal controller cares for the calculation of effective- and apparent power as well as -energy and power factor $\cos \phi$ and offers all its values in the process image. Also the calculated energy sums are to find there.

PM-E-Mess UI

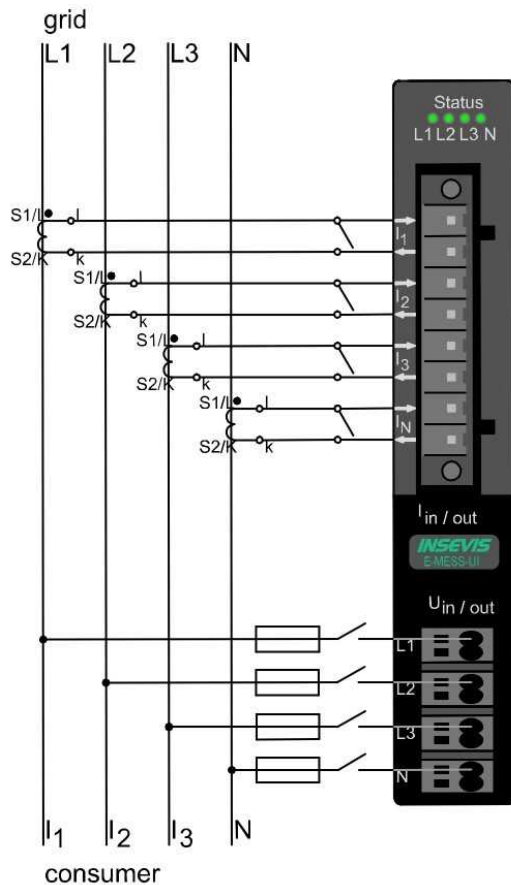

Both connectors for that module are part of the delivery.

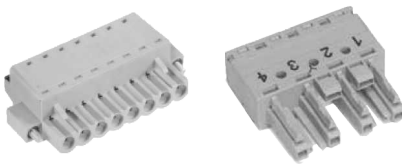

Hints:

Both connectors for that module are part of the delivery. Because of its specific connectors these modules can be used on CC3xxV and DP3xxC only.

More product information to this module is available at INSEVIS web sites in the Product / Periphery - area and contain more information for wiring and data access in the periphery image.

General

Property	Technical data
Use in lower and medium voltage grids	yes
Load voltage L+	Internal connected by device supply
Protection class	I
Degree of pollution	2
Power frequency	50 Hz, 60Hz switchable

Voltage measurement

Property	Technical data
3-Phase 4-Wire systems with rating voltage (L -N)	Up to 230V eff.
Overvoltage category	300V CAT III
Rated impulse voltage	4kV
Measurement range L-N	Up to max. 350V eff.
Impedance	1 MΩ / Phase
Resolution	0,1 V
Measurement precision (typ.)	0,5%
Sampling frequency	8 kHz
3-Phase 4-Wire systems with rating voltage (L -N)	Up to 230V eff.

Current measurement

Property	Technical data
Rated current	1 / 5 A
Measurement range	0 - 6 A eff.
Impedance	14 mΩ
Resolution	0,1 A
Measurement precision (typ.)	0,5%
Sampling frequency	8 kHz

Order data	Article no.
Periphery module E-Mess UI	PM-EMESS-UI-02







Valid list prices on request from your local INSEVIS-distributor.



Accessories for periphery

There are available pin marked removable connectors either with lift arms or with bolt flanges to connect INSEVIS- devices. This allows a explicit positioning of each pin to the signals and makes the wiring easier. The wire-contact is done by maintenance free cage-clamps for max. 1,5mm² cross sections without wire end sleeves.

A grounding terminal is part of every delivery of head stations. Every periphery module contains the referring rear foil, standard inserting and signal stripes.

Figure of accessories	accessories	Article no.
<p>Connectors</p>  <p>E-CONS10 bolt flanges (pin marked connectors for max. 1,5mm² cross sections)</p>	<p>For head stations</p> <p>Connector 2x5pin, bolt flanges (mechanically compatible replacement for discontinued E-CON10)</p> <p>Pin-Numbers are printed on the sides.</p>	E-CONS10-00
 <p>E-CONS20D bolt flanges (pin marked connectors for max. 1,5mm² cross sections)</p>	<p>For digital and mixed modules</p> <p>Connector 2x10pin, bolt flanges (mechanically compatible replacement for discontinued E-CON20D)</p> <p>Pin-Numbers are printed on the sides.</p>	E-CONS20D-00
 <p>E-CONS20A bolt flanges (pin marked connectors for max. 1,5mm² cross sections)</p>	<p>For analog modules</p> <p>Connector 2x10pin, bolt flanges (mechanically compatible replacement for discontinued E-CON20A)</p> <p>Pin-Numbers are printed on the sides.</p>	E-CONS20A-00
 <p>E-CON08 (connector for max. 1,5mm² cross sections)</p>	<p>For relay module DO4R</p> <p>Connector 1x8pin</p>	E-CON08-00
 <p>E-CON34 (pin marked connector for max. 1,5mm² cross sections)</p> <p>E-CONS34 bolt flanges (pin marked connectors for max. 1,5mm² cross sections)</p>	<p>For DP301 (periphery) only:</p> <p>Connector 2x17pin, lift & lock arms or Connector 2x17pin, bolt flanges</p>	E-CON34-00 or E-CONS34-00
 <p>E-CON06 bolt flanges</p>	<p>For DP301 (bus and supply) only:</p> <p>Connector 2x3pin, bolt flanges</p>	E-CONS06-00
<p>Customized labeling</p>	<p>Inserting stripes V with customer logo (rear)</p>	E-LABV-00
<p>Software</p>	<p>ConfigStage</p>	-
<p>Spare parts</p> <p>Hint: grounding terminal is part of every delivery</p>	<p>Additional grounding terminals</p>	E-MNT00-00

Attached parts, customized designs and valid list prices on request from your local INSEVIS-distributor.



Software



Solve complex tasks in the almost easiest way

You do not need 2 monitors or a super computer to run INSEVIS software. Be sure to get right along after months doing other jobs. And protect your intellectual property so that it stays yours. It is easy with INSEVIS software read and/or write protection. Paying for licenses? Not necessary for standard software, what allows the whole functionality with one project language.

INSEVIS software stands for the solution of complex tasks in an easy and intuitively logical way. No gadgets, no vanilla, just simple ways to create innovative automation without studying miles of manuals. No matter, if you work in the office or with you lap top to place your machine into operation. Installed in a few minutes, nearly no hardware requirements and always to run on small monitors as well.

All functions are explained in manuals or directly in embedded tool tips. Program lines for INSEVIS-SFCs are integrated in the manuals. Every panel is delivered with a sample visualization, what is explained in detail in the manuals and available as source file at INSEVIS web sites. Handling and introduction videos are available in playlists at the INSEVIS YouTube-channel.

Products

Configuration tool



Parametrize of periphery, communication and CPU
– ConfigStage

Visualization tool



Creating, simulating, debugging of extensive visualizations
– VisuStage Lean version
– VisuStage Full version

Remote access tool



Portable software for remote visualization and data backup
– RemoteStage

Service tool



Simple tool for diagnostic, maintenance, know-how-protection
– ServiceStage

Fields of application

- Configuration and addressing of INSEVIS periphery,
- Mapping of external periphery by CAN or Modbus,
- Configuration of S7-CPU alternatively to SIMATIC®-Manager or TIA-Portal®,
- Creation of a high-class visualization including archives,
- Free remote visualization of Siemens-CPU's like at a 2nd panel, large screen, master screen, etc.
- Display and save archives (also in a batch process), edit and download receipts,
- Diagnostic, backup, restore and update PLCs, activation of the know-how protection

Communication between PLC and panel

INSEVIS software communicates to the INSEVIS PLC and Panel-HMI by TCP/IP. The software finds network partner automatically and can indicate it by a blink test.



External memory card

If new functions in the S7-program or visualization need an firmware update of PLC/HMI, this can be done by an Micro-SD-card in the standard FAT32-format. Also this card is needed for archiving or updating only, not to run the S7-program. Use this card only for archiving of message data, of data from DBs, of trend data as well as of data of the recipe management and for backup/restore. While updating the PLC- firmware by this card, the S7-data will kept untouched - as they were before.

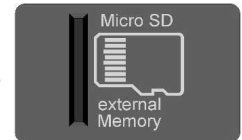

Most important properties at a glance

<p>Data archiving</p> <p>Save and archive process data to the Micro-SD-card and read it back to the PLC after updating S7-program. Completely without programming device - by using INSEVIS-SFCs and SFBs. To satisfy the customers for lots of years.</p>	<p>Backup & Restore</p> <p>Save all data easily; user program, process data, visualization and archives - protected by password as a binary file for using in an equal equipped device, what will proceed with all data from the old PLC</p>
<p>Unlimited languages</p> <p>INSEVIS supports all languages, what are installed on the PC, where the visualization is designed. No limitation of the number of used languages in the visualization-run-time. Always Unicode16-able. Always be at home in every language of the world.</p>	<p>Free remote account</p> <p>Use your PC-screen as 2nd panel to display and control your application remote. Import and save archive and recipe data as txt- or csv- files. Do it in a multi-instanceable way in your PC, like in a master display of a control room.</p>
<p>Trend management</p> <p>4 time based trends with 16 channels each can be started, stopped and continued manually or by variables. Display and archive it as you want it to do. Or display x;y-value couples from DBs in function graphs</p>	<p>Multistructured recipes</p> <p>Create up to 64 recipes with up to 256 different variables (elements), what result up to 256 data records per recipe. Export, edit it at the PC and re-import recipes, records and elements by Ethernet and via the Micro-SD-card.</p>
<p>Fault indicating system</p> <p>Display, indicate and archive up to 1024 alarms and 1024 events in all your project languages, as blinking text line or symbol, as single- or multi-line message viewer and -archive. Export this data automatically as csv-file to any network drive.</p>	<p>User management</p> <p>Manage up to 9 user levels by run-time editable PINs. Define user based target screens and change screens depending on user level. Allow or deny access to „hot keys“ as you want to.</p>
<p>Integrated simulation</p> <p>Compile your new visualization, get the detailed, linked failure report to debug it fast. Simulate your visualization immediately and stimulate variables, alarms and events. Make your screen shots in jpg-format for your documentation.</p>	<p>Import & export functionality</p> <p>Import S7-variables including symbols from your SIMATIC®-Manager and TIA-portal. Export your texts for an external translation as simple csv-file and read it back into the project.</p>



Software

ConfigStage

This cost free tool equalizes the difference between INSEVIS devices and Siemens-configuration, so that you can address INSEVIS periphery and use INSEVIS communication interfaces with SIMATIC®- Manager or TIA-Portal®. All the configurations of additional functions will be done here too and are permanently checked for addressing errors by the program itself.

The whole configuration is done intuitively in a graphic way. Periphery modules were placed on their slots by drag'n drop, decentral peripheries to the CAN-interface of the CPU. Then it will be configured and parametrized and the whole configuration will be compiled into a binary file. This binary will be downloaded by Ethernet into the PLC hardware system blocks. The programming by SIMATIC®- Manager or TIA-Portal® will be not affected by this procedure.

The mapping of CAN-specific data to S7-area allows a very clear and simple integration of external periphery by using the comfortable EDS (ElectronicDataSheet of CAN-slaves) -import function. All can be saved in a library to create future projects by drag'n drop. This makes the ConfigStage to one of the finest examples of an practical, smart and simple integration of external CANopen®-slaves into the S7-world.

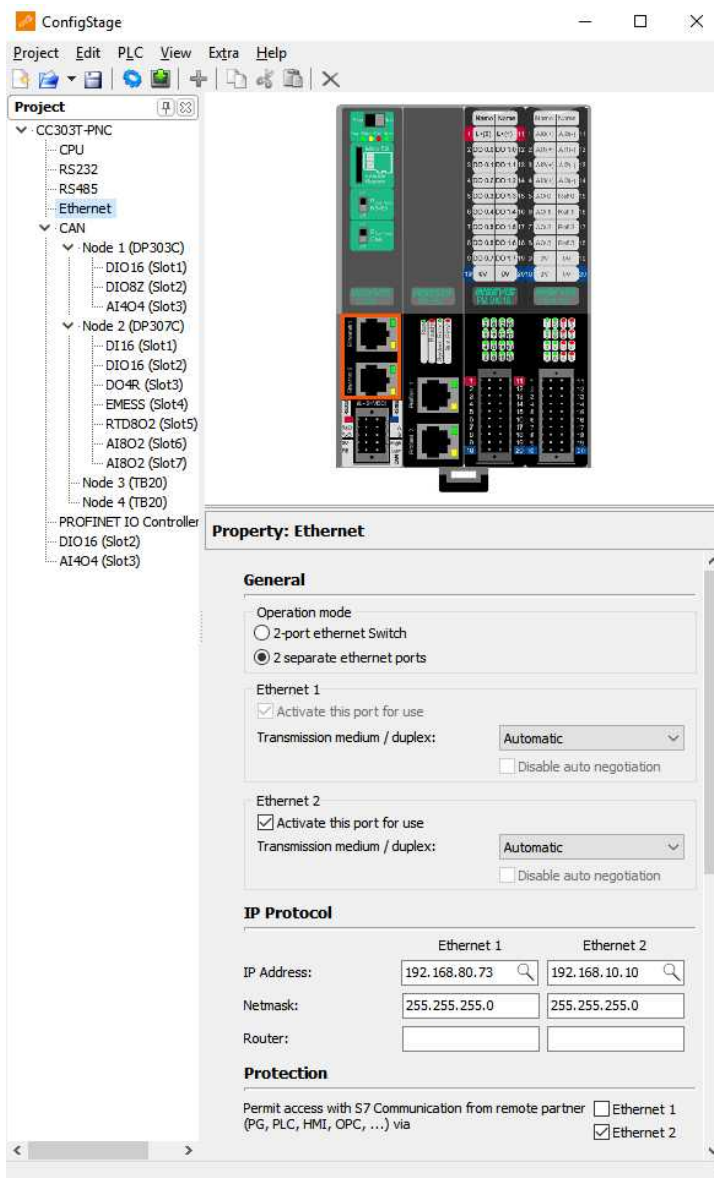

Image: Configuration of separated IP-address areas

Hint: free download of the latest version at the INSEVIS web sites in the field products → software

Property	Technical data
Operating system	Windows XP Windows 7 Windows 10
Hardware requirements	Min. 5MB free disc space Monitor min. SVGA (800x480)
Installation time	< 1 minute
Operating languages	German and English
Monitoring of address conflicts	Automatically permanently (in the background)
Data formats	csproj (source file) csbin (binary file)
Configurable S7-control parameter of the S7-CPU	Startup behavior Password protection Cycle time monitoring Retentive memory Time-Of-Day interrupt Cyclic interrupt
Configurable interfaces	RS232: free ASCII RS485: free ASCII ModbusRTU Ethernet: RFC1006 (S7-communication) TCP, UDP, Modbus-TCP, Panel-HMI CAN: CANopen® (EDS-import)

Address overview

Input and Output address overview

Type	Address	Module	Node	Slot
Input	4 .. 5	DIO16		2
Output	4 .. 5	DIO16		2
Input	160 .. 167	AI404		3
Output	160 .. 167	AI404		3
Input	6 .. 7	DP303C.DIO16	1	1
Output	6 .. 7	DP303C.DIO16	1	1
Input	10 .. 21	DP303C.DIO8Z	1	2
Output	10 .. 21	DP303C.DIO8Z	1	2
Input	128 .. 143	DP303C.AI404	1	3
Output	128 .. 135	DP303C.AI404	1	3
Input	22 .. 23	DP307C.DI16	2	1

Image: Overview about I/O address areas

Ordering data	Article no.
Software tool „ConfigStage“	None / free download



ServiceStage

The cost free software tool ServiceStage is developed for the maintenance crew, what need to make diagnostics and updates on existing controllers. For that not expensive hard- and software is need, only this ServiceStage. The controller can be found and indicated by Ethernet easily.

There is no risk of illegal data loss, because this software uses no source files, it downloads WLD-file (S7-program) and binaries (visualization and configuration) to the PLC. And another security option worth to think over: uncrackable read or read/write protections. No password, only deletable by downloading an unprotected program, what only the real owner has.

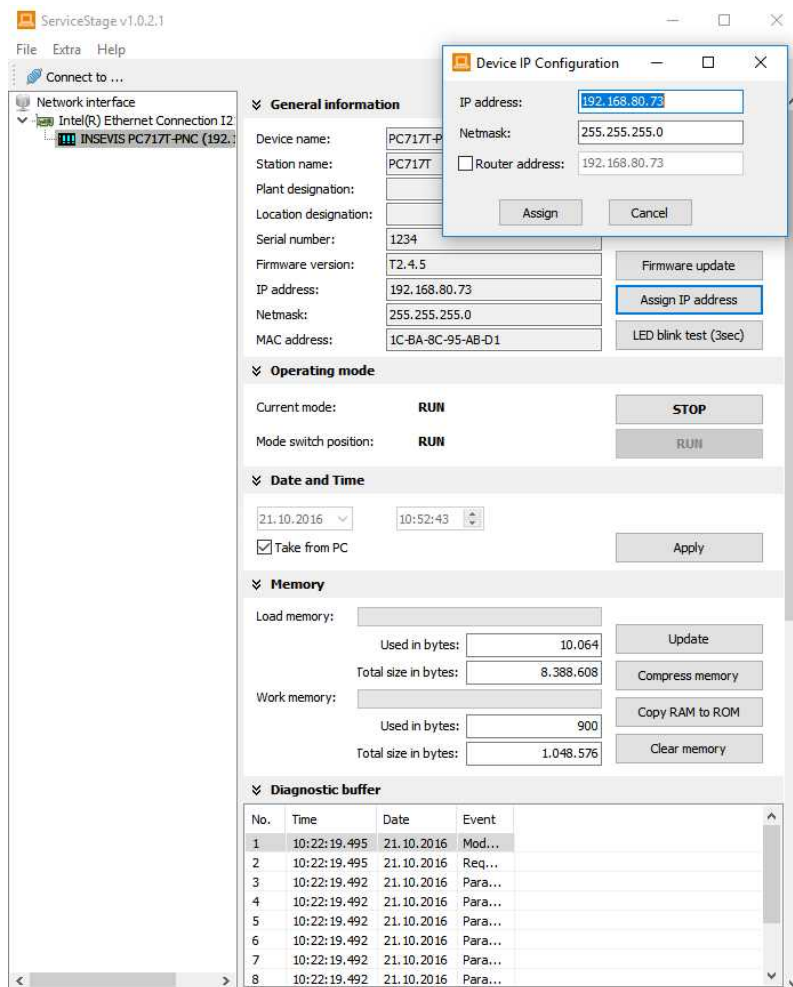

Image: Change IP-address of remote device by ServiceStage

Property	Technical data
Operating system	Windows XP Windows 7 Windows 10
Hardware requirements	Min. 5MB free disc space Monitor min. SVGA (800x480)
Installation time	< 1 minute
Operating languages	German and English
Service functions	Firmware update (CPU-T) Identification of the target device in the network Read device specific data (Ser.-no., firmware version, IP-address (editable), MAC-address, etc.), Change of the operating mode RUN ↔ STOP, Set and synchronize date and time Memory diagnostics and -compression Read and save diagnostic buffer of the CPU Download of the S7-programs, of the visualization and configuration binaries Automatic creation of Backup data files Set know-how-protections Read / Read/Write

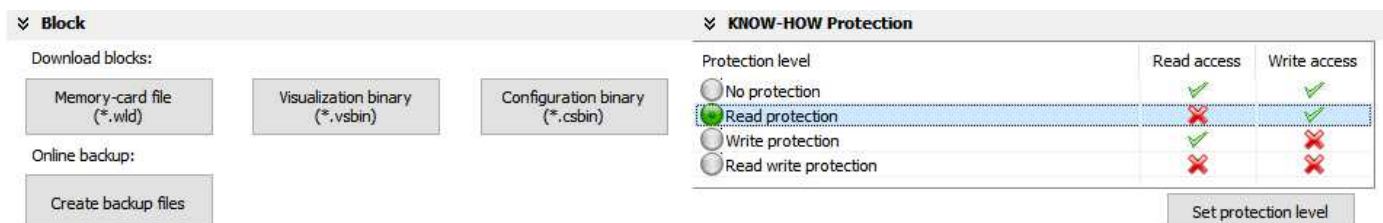

Image: Block download, backup file creation and Know-how protection

Hint: free download of the latest version at the INSEVIS web sites in the field products → software

Ordering data	Article no.
Software tool „ServiceStage“	None / free download



Software

VisuStage

With the VisuStage PC visualization tool, modern multilingual visualizations can also be easily created by newcomers. Existing S7 variables, including symbols, are taken from the DBs of the S7/TIA project and synchronized with them again and again. Export and import functions for texts make translation into foreign languages much easier. An integrated simulation is carried out manually or together with the S7/TIA project from the Siemens S7 PLCSIM. Users of WinCC-TIA and WinCCflex® from Siemens immediately are familiar and WinCC-TIA projects can be adopted for the most part. With the Edge HMIs, the existing visualization can be converted to web visualization by one mouse click...

There is a cost free version with all functions and one language only, what is enough for a simple visualization. Those, who need more languages pay a very low company license for endless number of installations in their company. After first installation the VisuStage runs 30 days in full language-mode and than works on as cost-free single-language version. A yearly company maintenance license secures that always the latest version with the newest features can be used in the whole company. Those, who do not like maintenance, work on with the last installed version of their company or with the free license.

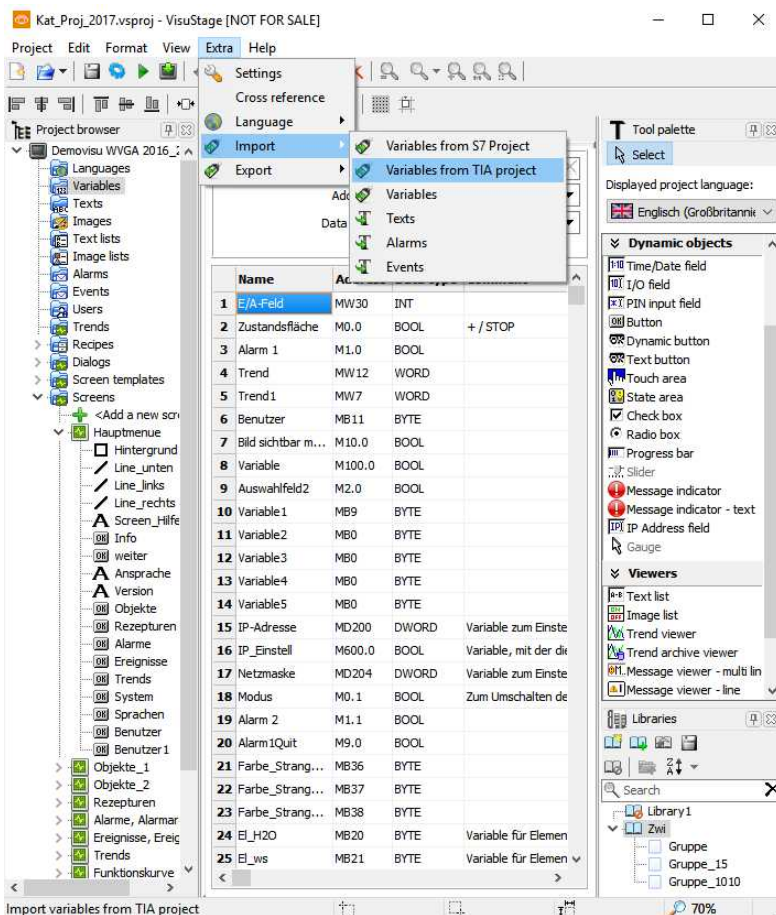

Image: Variables import from TIA-project

Property	Technical data
Operating system	Windows XP Windows 7 Windows 10
Hardware requirements	Min. 30MB free disc space Monitor min. SVGA (800x480)
Installation time	< 2 minutes
Operating languages	German and English
Data formats	vsproj (source file) vsres (resource) vsbin (binary file)
Number of languages	Unlimited (Full version*) 1 language (Lean version) * (all languages, what are installed on the VisuStage-PC)
Export- / Import-functions	For Variables, common texts and message texts and for images (bmp, jpg, png)
Error message system	Max. 1024 alarms, (archivable) Max. 1024 events, (archivable)
Trends	4 trends with 16 Channels each
Recipe management	Max. 64 recipes with max. 256 elements in max. 256 data records
User management	9 layers PIN-identification
Screen functions	Screen saver, dim and switch off backlight
Buzzer	Warn and click tone
Library function	Integrated
Simulation	Integrated, with stimulating of variables, message simulation and screen shot function

**KEEP S7
SMART &
SIMPLE**

With the free VisuStage tool you can create a modern and large up to 3.000x3.000 pixel sized, free defined visualization and save as binary file. This binary can be opened in remote-PC by free RemoteStage and can be connected by Ethernet with a Siemens-S7-CPU to get the process data from it. This visualization is free! No RunTime-License, no PowerTags!

Hint: free download of the latest version at the INSEVIS web sites in the field products → software



VisuStage

Using the projecting of trends it is easy to understand how simple the handling of the VisuStage software is.

To configure the trend resource data formats, variables, value area and design of the trend channels are needed as well as the conditions to start the sampling, the number of samples, its interval and the number of archived trend samples on the Micro-SD-card (up to 650.000 samples per trend channel are possible).

In the display of the Panel-HMI, the Panel-PLC respectively on a remote-PC a trend- or a trend archive viewer like below will appear by the simple settings before.

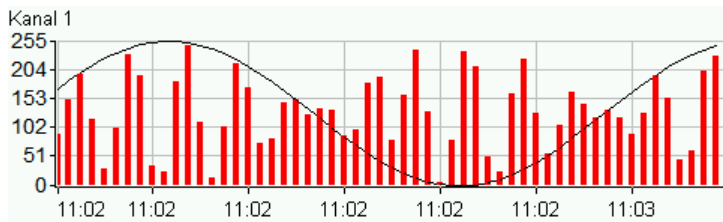

Trend viewer

channel 1
Value (1): 55

channel 1
Value (2): 113

Single trend curves (channels) can be (de-) activated by a hook in a check box, their values at a common time base and be displayed in I/O-fields, a ruler can be moved at the time axis to display values of trends at that time, zoom in and out functionality is available too.

Trend

Name: Druck

ID number: 6163

Data type: WORD

Comment:

Samples: 1000

Start behaviour

By demand (e.g Trend start function)

By system startup

By boolean variable change (not assigned)

Sampling interval: 1

By start

Append to existing samples Clear the existing sample

Archive

Enable 10000 samples in archive

Circular archive Segmented circular archive 10 segments

Channels:

Name	Variable	Min.	Max.	Deci...	Color	Style	Point
1 Kanal 1	Trend (MW12, WORD)	0	255	0	Black	Interp...	(none)
2 Kanal 2	Trend1 (MW7, WORD)	0	510	0	Red	Bar	(none)

Objekte 2

Status:

Wasser 0°C, Motor 70°C, Katalyse 30°C, Öldruck 5

Alarme

Index	Meldungstext	Zustand	Quitt.
1	Alarm 1 hat ausgelöst	<input type="checkbox"/>	<input type="checkbox"/>
2	Alarm 2 hat ausgelöst	<input type="checkbox"/>	<input type="checkbox"/>

Ereignisse

Index	Meldungstext	Zustand
1	Meldetext zu Ereignis 1	<input type="checkbox"/>
2	Meldetext zu Ereignis 2	<input type="checkbox"/>

Variablen

Variablen	Statuswert
1 MW1	0
2 MW350	1031
3 MB11	0
4 MW340	90
5 MW330	90
6 MW332	70
7 MW334	80
8 MW336	50
9 MW338	40
10 M300.0	1
11 M300.2	0
12 M300.1	0

The integrated simulation will be done by the SimuStage, a second instance or the VisuStage program.

In the variable table all variable used in the showed screen will be simulated manually. Alarm- and event messages can be triggered and confirmed as well.

A screenshot function creates jpg-images in order to use it for a proper documentation of the machine.

Ordering data	Article no.
„VisuStage“ Company license full version	SW-VS
„VisuStage“ full version one year maintenance license	SW-VSW
„VisuStage“ full version three years maintenance license	SW-VSW3

For unlimited number of installations of the multi linguistic version and access to updates for the first year.

Access to updates for existing installations of the multi linguistic version for one more year (after the first year).

Access to updates for existing installations of the multi linguistic version for three more years (after the first year).

Valid list prices on request from your local INSEVIS-distributor.



Software

RemoteStage

This program is available as command line tool only, it means it doesn't need be installed. The RemoteStage opens a local binary file of visualization project, what was made by VisuStage (or can import/upload it from INSEVIS-Panel-HMIs/ -PLCs into the remote PC) and opens up a S7-connection (Put/Get) to a S7-PLC of other brands too. Than it gets the process data from this CPU and displays it in the local visualization. There incur no software costs like runtime-licenses or power tags. So respectively you can **visualize Siemens-S7-CPUs for free remote**, just insert IP-address and TSAP, allow „Put/Get“ in TIA - ready.

Ideas for creating use cases with free remote visualization of S7-PLCs

Open a VisuStage visualization binary by RemoteStage on the desktop-PC, connect the S7-PLC and create an additionally **add-on display**.

As long the remote PC is connected with the S7-PLC, there can be sampled additional trend out of the process data, such as for service actions as temporary **data logger**.

There can be running multiple instances of remoteStage on the remote PC side by side to get multiple PLCs visualized in one scree, like a **Master display**.

If RemoteStage runs at a mobile Windows-tablet what is connected with the PLC by WLAN, a low budget **mobile operator panel** is created.

Imagine to call RemoteStage at a Windows-Box-PC, who is connected with S7-PLCs and to a wide TV-screen, than this could be a low budget **large screen** application.

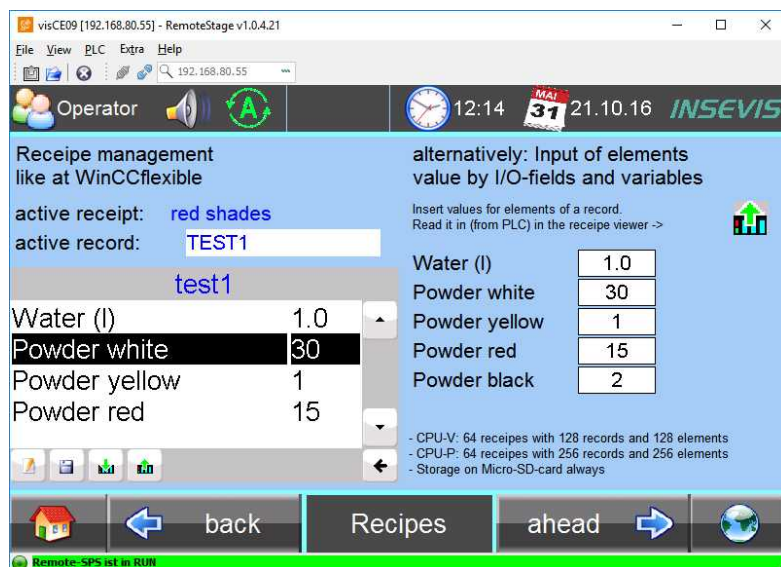
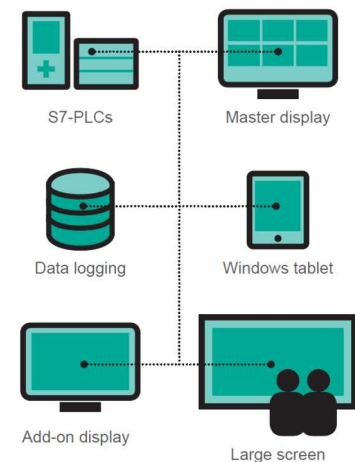

Image: Remote screen of a recipe management

Hints: free download of the latest version at the INSEVIS web sites in the field products → software

The VNC-client is not part of the RemoteStage (To use the VNC-server of the CPU-T-devices a VNC-viewer/-client is necessary, what is available as app or PC-program separately from different suppliers)

**KEEP S7
SMART &
SIMPLE**

At the download area of INSEVIS web sites there is a well-documented sample description with a full-HD-visualization and corresponding S7-programs for S7-1200/1500 as well as S7-300/400. So you can test in a few minutes by your own Siemens-CPU how easy this cost free visualization works.

Property	Technical data
Operating system	Windows XP Windows 7 Windows 10
Hardware requirements	Min. 2MB free disc space Monitor min. SVGA (800x480)
Installation time	None, it is an execute file
Operating languages	German and English
Remote visualization of following archives at Panel-HMI	1024 alarm archives, 1024 event archives, 4 trends with up to 16 channels each, 256 recipe data records with up to 256 elements,
Remote visualization of following archives at Panel-PLC	1024 alarm archives, 1024 event archives, 4 trends with up to 16 channels each, 256 recipe data records with up to 256 elements, Data (DB) -archives
Remote visualization of following archives at Compact-PLC	Data (DB) -archives
Format of the saved archive files	csv- format
Batch processable	yes
Multi instanceable	yes



RemoteStage

The archive mode, a second instance of the RemoteStage, imports, opens up and converts to csv all the archive data from the Micro-SD-card of INSEVIS Panel-HMIs and -PLCs by Ethernet (or by inserting the ejected Micro-SD-card from the device into the remote PC).

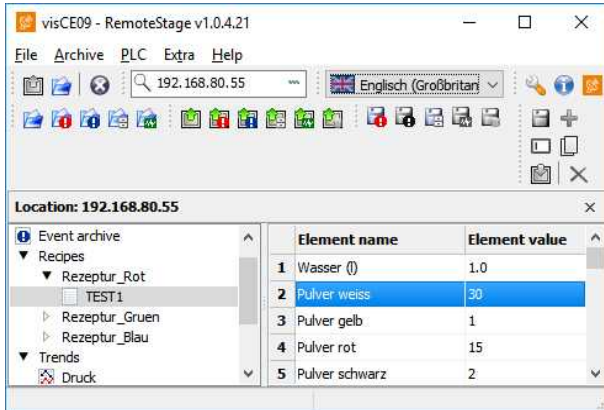

Image: Recipe editing on PC with RemoteStage

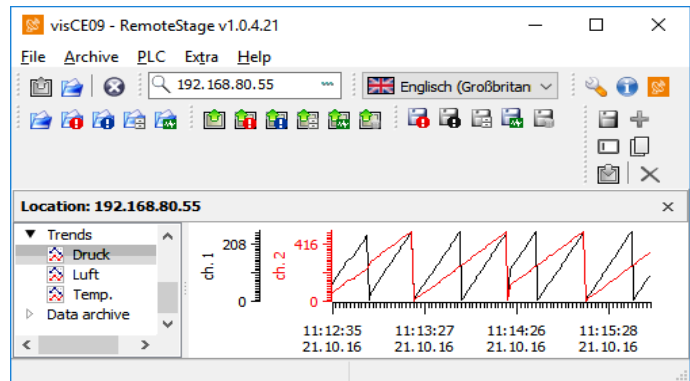

Image: Trend viewing at RemoteStage

By using the RemoteStage as command line tool it can be called with different parameters and supply following functions. These parameters can be written into a batch file and be inserted into the "Autostart" of the remote PCs (to run always) or into "planned tasks" to run at defined times only such as for regularly backups.

- ✓ **Automatic connecting to remote panel after starting PC**
With his function a binary of the visualization is called and linked with the predefined IP-address of the remote panel (if this is available online only)
- ✓ **Automatic full screen after starting PC**
With his function a binary of the visualization is called and the RemoteStage changes into full screen at the remote PC after automatic starting (Screen stays dark, because no IP-address was assigned here...)
- ✓ **Set up TCP port number for S7-communication**
If there are multiple PLCs to connect by a web enabled router/ gateway with port forwarding service
- ✓ **Read in (upload) message- and trend archives from remote device**
The binaries of the messages and trends (assigned in the VisuStage before and created at runtime) will be read in, converted and stored in a path on the PC.
- ✓ **Read in (upload) recipe archive from remote device**
The binaries of the (in VisuStage predefined) recipes and the of the records (created in runtime by the operator or by SFC206 from the S7-program) will be read in, converted and stored in a path on the PC..
- ✓ **Write back (download) recipe archive into remote device**
With this function the uploaded (and maybe modified) recipe data will be written back (downloaded) into the remote device.
- ✓ **Read in (upload) data (DB-) archive from remote device**
This function copies the data(DB-) archives created by S7-program with SFC207 to the requested target path into the PC. A modification of the csv-format is not possible.
- ✓ **Write back (download) data (DB-) archive into remote device**
With this function the uploaded (and maybe modified) data (DB-) archives will be written back (downloaded) into the remote device.

Ordering data	Article no.
Software tool „RemoteStage“	None / free download



Energy management



INSEVIS S7-energy management – simple to create and to expand – always

INSEVIS products stand out of the multitude of energy meters: By an EMB-safe metal cover, by its simple programming and by its expansive visualization. It was never that easy to sample energy data and to integrate these data into the S7-automation environment. Forget about mounting black boxes for metering every consumer – collect it all in one PLC, display it remote at the head offices PC and provide all required data directly to the OPC by S7-protocol.

Equal if it is used for sampling voltage or current, for calculating power or energy data by E-MESS UI or for continuous controlling of residual currents with E-Diff or for an intelligent reduction of power peaks to optimize the energy contract situation; these products offer multiple benefits for every S7-programmer. With these products every S7-programmer can realize this solution easily with his basic knowledge now.

Products

Energy sampling by E-Mess



Sampling of current and voltage values for L1, L2, L3 and N with:

- all PLC with CPU-V
- all DP303/303/311C
- PM-E-Mess-UI

Reduction of power peaks by E-Max



Optimizing of load times by switching off consumers with:

- all PLC-V/-T
- all DP303/303/311C
- PM-DIO16

Fields of application

- Integration of energy metering directly into the S7-PLC of each application,
- providing energy data directly to OPC by S7-protocol,
- Energy monitoring ref. to EN ISO 50 001 / DIN EN 16 247,
- Optimize power peaks to optimize the energy contract situation,
- Continuous measurement of residual currents as fire precautions in buildings



System topologies – exclusive solutions for power metering or load management

There are separated applications for energy metering by E-Mess UI- periphery modules and load management for selected consumers.

Instead of using multiple energy meters as single devices and to cut out multiple holes for that it much is easier to realize this solution by multiple periphery modules in one PLC or expand it on decentral periphery blocks with more E-Mess beside the PLC in the main power distributing cabinet. All the sampled and calculated data can be transferred by S7-protocol directly to OPC – with the basic knowledge of each S7-programmer.

For the load management is an Ethernet-based connection very important, because there can be connected subsidiaries far away easily. They receive their energy data by digital pulses or from other energy meter by Modbus (serial/RTU or Ethernet/TCP). The expansive consumer configuration (priority, minimum Off/on-times, groups, etc is done once remote).

E-Mess topology (exclusive energy metering)

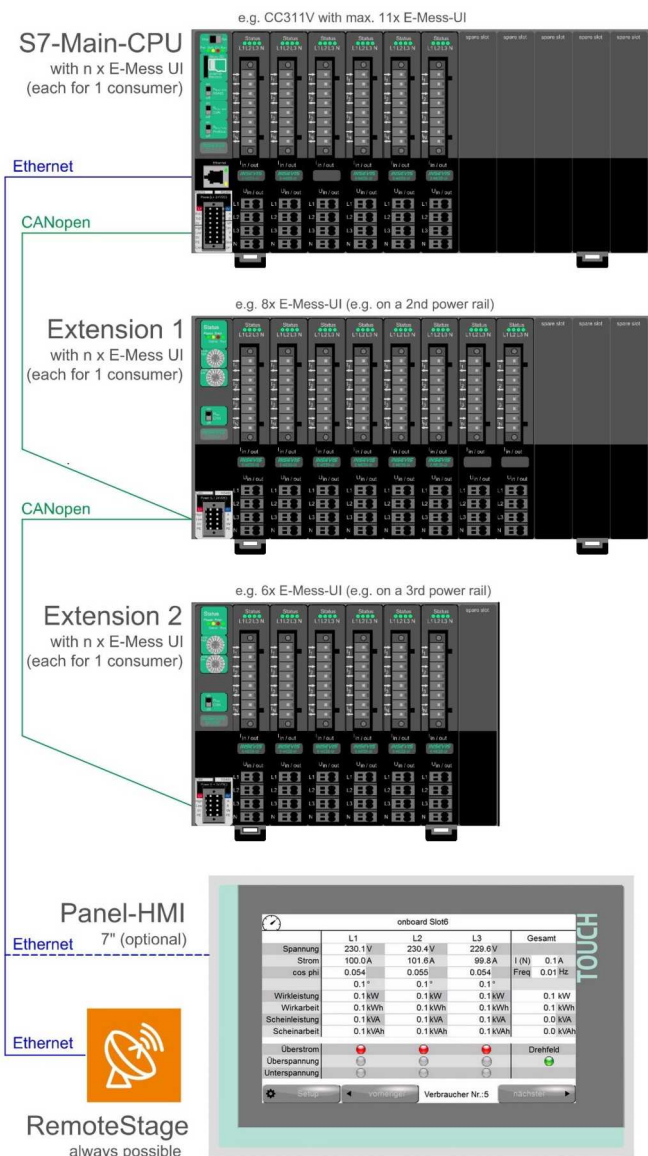

E-Max topology (exclusive load management)

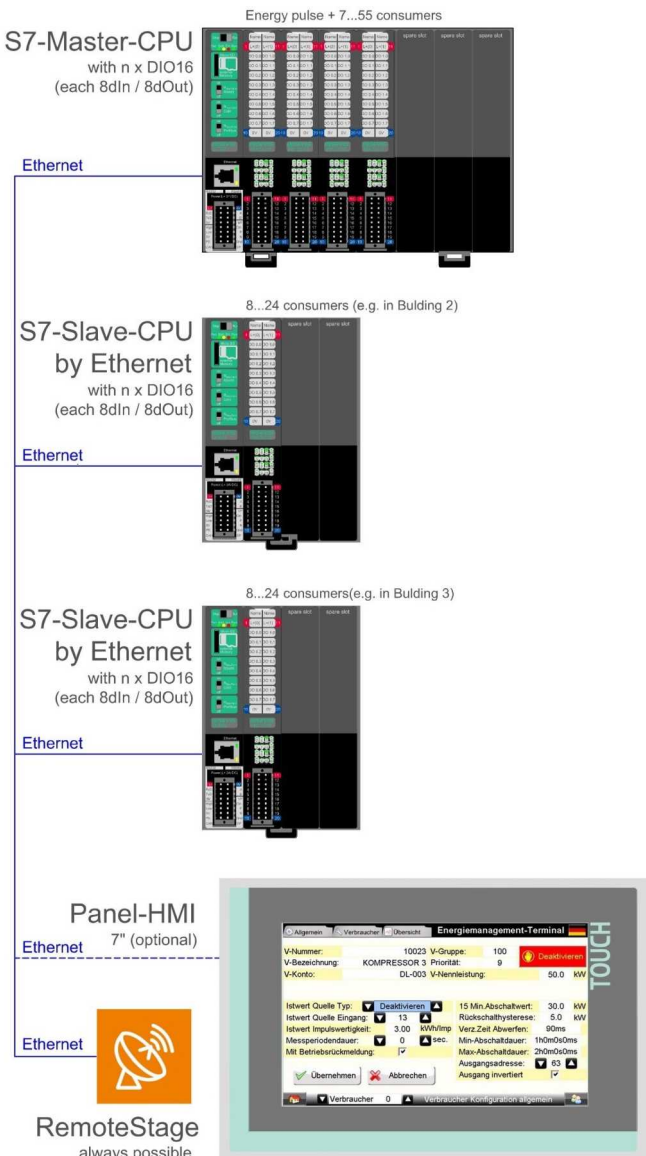

These both topologies are shown as samples of the respectively exclusive application for

- **energy metering** (measurement with adding and storing as energy balance ref. DIN EN ISO 50 001)
- OR as
- **intelligent load management** (with receiving power data from external data by digital signal or Modbus RTU / TCP).

Therefore are available free sample programs and visualizations at the download area of INSEVIS web sites.

Alternatively exist expansive S7-programs and visualizations as complete solution as license, containing consultancy of qualified programmers on request. You will be assisted by certified distributors of INSEVIS, who all service from provide methods of solutions, offer, delivery and finally implementing and bringing into operation as well.



Energy management

System topologies – mixed solutions for power metering and load management

In the most applications both solutions were needed in a single system (e.g. energy metering by E-Mess UI- periphery modules and just with these data load management for selected consumer by a periphery module DIO16). Additionally residual currents can be controlled continuously with a periphery module E-Diff (up to 8 currents with a single module) and can be processed by an individual S7-program made with common S7-knowledge. With only a single periphery module E-Mess UI a solution can (beside its designate us of machine controller) provide its energy balance to the superior control system (OPC).

E-Mess- / E-Max topology (mixed energy metering and load management)

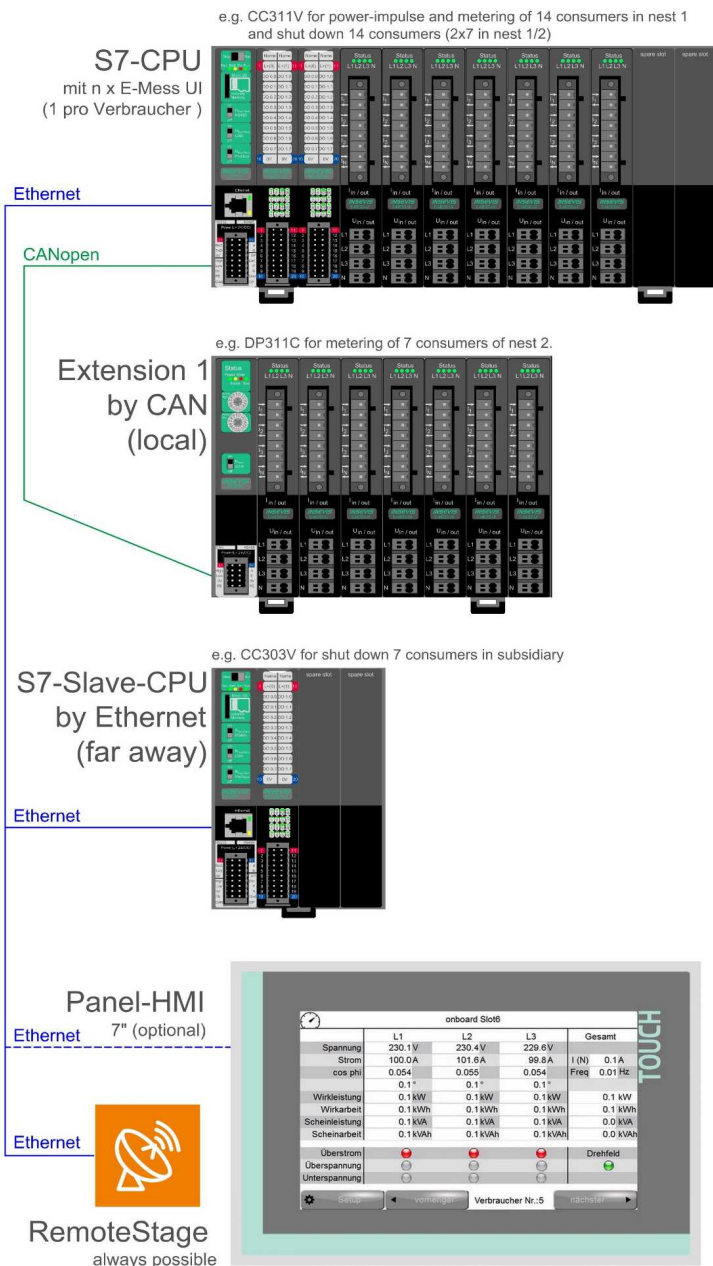

This topology shows a sample of the respectively exclusive application for

- **energy metering** (measurement with adding and storing as energy balance ref. DIN EN ISO 50 001) **AND** as
- **intelligent load management** (with receiving power data from external data by digital signal or Modbus RTU / TCP).

Therefore are available free sample program and visualization at the download area of INSEVIS web sites.

Alternatively exist expansive S7-programs and visualizations as complete solution as license, containing consultancy of qualified programmers on request. You will be assisted by certified distributors of INSEVIS, who all service from provide methods of solutions, offer, delivery and finally implementing and bringing into operation as well.



S7-IIoT-Gateway



INSEVIS-S7-IIoT-Gateway – compatible but independent up to the cloud

INSEVIS is known for independent and sustainable solutions in the S7-world. So, why not expand this solutions to the „Industrial Internet of Things“ or „Industry 4.0“? Our huge know-how for S7-technology, combined with most modern security-, communication- and operation philosophy allow optimal combination of S7-solutions with the big-data-world on one side and, secure connections between S7-islands completely without a portal or a cloud.

Referring to the „Reference Architecture for Machines at Industry 4.0 – RAMI4.0“ INSEVIS supplies all configuration shells onboard, so that a single browser is enough to assign and configure all the settings. But not for anyone, because a sophisticated user management cares for a considerably protection and allows released connections only. External access is possible by openVPN in a safe way.

The benefit of the INSEVIS S7-IIoT-Gateway is, that the integrated NodeRED-configuration tool opens up a wide variety of additional functionality for NodeRED-programmers. The IIoT-Gateway provides S7-datapoints to the NodeRED configurator and then it is your turn to create what you and your customers want. You can let you imagination run; create tweeds, emails or convert text to speech, etc...

S7-IIoT Gateway functions in the INSEVIS EDGE HMIs

The EDGE HMIs from INSEVIS are effectively the link between IIoT gateways and S7 HMIs. All the functions of the gateway are also available to the EDGE HMIs. This includes web visualization, for which no project planner needs to be able to program HTML5 and JavaScript. This is automatically converted from a visualization created conservatively with VisuStage.

Fields of application

Add S7-controllers by OPC UA-interface to I4.0

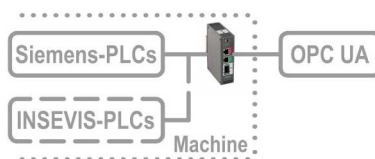

Secure integrating of the S7- Welt by OPC UA to MES, HMI, SCADA ref. to RAMI4.0 (administration shell)

Data acquisition, -processing and -forwarding by IIoT

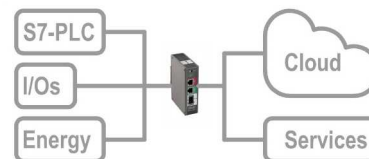

Data acquisition in S7- and field-layer and transfer by OPC UA or MQTT into cloud or by FTP, email, Twitter, etc.

Secure connection of PLC-islands without Cloud/Portal

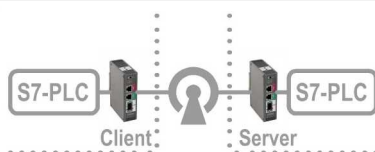

By Site-To-Site-open-VPN directly and secure client/server connection of two S7-islands without need of a clouds or portal

Secure remote maintenance of multiple systems

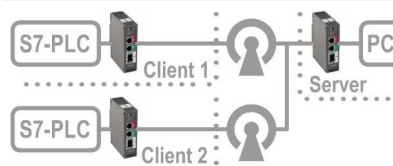

Secure remote maintenance of multiple S7-islands by openVPN from a central station



Communication in LAN and WAN

The S7-IloT-Gateway communicates to control- and field-layer by Ethernet RFC1006 (S7-communication as active Put/Get) and Modbus-TCP. CANopen, RS485 (Modbus-RTU) and by RS232 (Modbus-PTP) can be handled by NodeRED configuration.

At the WAN-side a firewall protects the device against unauthorized communication attempts. The Gateway offers OPC UA-server functionality (free or accordant to S7-definition of the namespace) for data exchange with SCADA-, MES- or other management systems. The MQTT-Client functionality (publishing/subscribing) allows the process data supply for cloud systems.

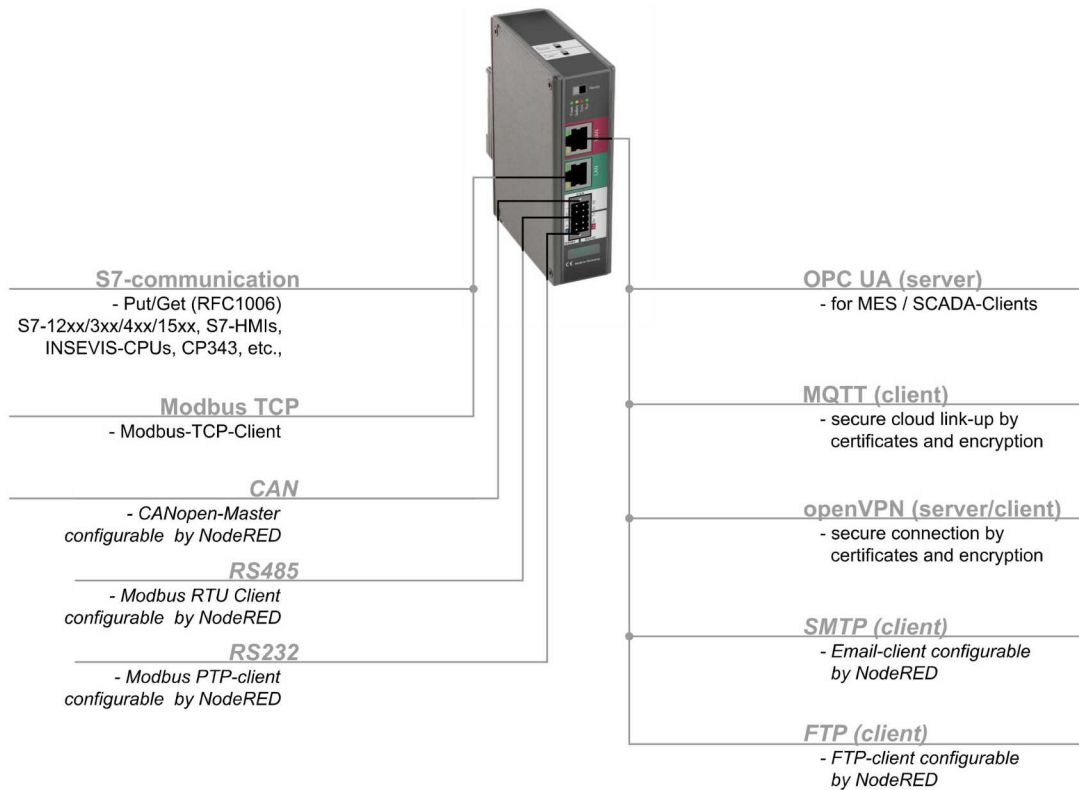

Most important properties at a glance

<p>LAN: S7-Ethernet and Modbus-TCP</p> <p>Communicate by RFC1006 (S7-communication Put/Get) easily and with all Siemens-S7-CPU's Integrate energy meters into your system by Modbus-TCP.</p>	<p>LAN: Modbus-RTU and CANopen</p> <p>Easy data exchange by additional protocols to communicate to different kinds of field devices like energy meters, decentral I/Os, FCs, etc. by NodeRED configured serial interfaces</p>
<p>OPC-UA: S7-variables import and register mapping</p> <p>Import S7-variables from Simatic-Manager or TIA-Portal including symbols and supply it as data point. Map Modbus registers to OPC UA-data points.</p>	<p>OPC-UA: free namespace</p> <p>Either create a namespace according to S7-1500 or create your own free namespace as an ideal image of your solution by OPC UA</p>
<p>MQTT: onboard configuration</p> <p>Simple configuration by implemented web configuration as publisher / subscriber, what is easy for non-programmers too.</p>	<p>openVPN: secure S7-communication</p> <p>Setup of openVPN-connections including certificate-management by onboard-configuration to connect 2 S7-islands completely without portal or cloud. Or as simple secure remote maintenance.</p>
<p>Web-Config</p> <p>One onboard-configuration tool saves all external PC-tools Secure access control by integrated user-management, comprehensive backup-, restore- and update functionalities</p>	<p>NodeRED</p> <p>Integrated and intuitively projection of additional services such as Twitter, FTP, email, text to speech trending, etc.) integrated dashboard function as additional visualization</p>



S7-IloT-Gateway

S7-IloT-Gateway GC300T



Hint:
More product information to this module is available at INSEVIS web sites

Property	Technical data
Operating temperature range Storage temperature range	-20°C ... +60°C (no condensation) -30°C ... +80°C
Dimensions W x H x D Weight	27 x 120 x 70 mm ca. 150 g
Working memory	256 MByte
Internal memory	4 GByte, thereof ca. 1 GByte for user data (visualization, etc.)
Programming language Programming system	JavaScript NodeRED
Serial interfaces (protocols by NodeRED)	COM1: RS232 COM2: RS485
CAN (via NodeRED)	with 10 kBaud - 1 MBaud
NodeRED (Limit at ~ 50 variables)	Data points from all other interfaces
Ethernet 10/100 Mbit (protocols) *max 2000 variables resp. max 32 kByte per PLC	S7-communication* (Put/Get) Modbus-TCP* MQTT, OPC UA
OPC UA Server * + max .100 user var. ** with external modeller	Namespace: compatible to S7-1500 * alternatively user defined ** Data points from all other interfaces with history configurable in sample time and number of samples
Subscriptions Monitored Items	max. 8 max. 500
Security policy	-none -Basic 256 Sha 256 sign / -Basic 256 Sha 256 sign & encrypt

Article name	Article number
S7-IloT-Gateway GC300T	GC300T-0-03
S7-IloT-Gateway GC300T Webvisu	GC300TW-0-03
Connector 2x5pin with bolt flanges	E-CONS10-00

Valid list prices on request from your local INSEVIS-distributor.

Copyright

This and all other documentation and software, supplied or hosted on INSEVIS web sites to download are copyrighted. Any duplicating of these data in any way without express approval by INSEVIS GmbH is not permitted. All property and copy rights of these documentation and software and every copy of it are reserved to INSEVIS GmbH.

Trade Marks

INSEVIS refers that all trade marks of particular companies used in own documentation are reserved trade marks are property of the particular owners like e.g.:

- STEP®, SIMATIC®, TIA-Portal®, WinCC-flex® and all other registrated trade marks of Siemens AG,
 - CANopen® and all other registrated trade marks of CAN in Automation eG
- and are subjected to common protection of trade marks.

Disclaimer

All technical details in this documentation were created by INSEVIS with highest diligence. Anyhow mistakes could not be excluded, so no responsibility is taken by INSEVIS for the complete correctness of this information. This documentation will be reviewed regularly and necessary corrections will be done in next version.

With publication of this catalog all other versions are no longer valid.

INSEVIS Vertriebs GmbH

Am Weichselgarten 7
D - 91058 Erlangen

Fon: +49(0)9131-691-440
Fax: +49(0)9131-691-444
Web: www.insevis.de
E-Mail: info@insevis.de

Zertifiziert nach DIN EN ISO 9001:2015